



HOW GREEN TRANSFORMATIONAL LEADERSHIP INFLUENCES SUSTAINABILITY? MEDIATING EFFECTS OF GREEN CREATIVITY AND GREEN PROCUREMENT

*Como a liderança transformacional verde influencia a sustentabilidade?
Efeitos mediante da criatividade verde e da compra verde*

Ashok Kumar Shah¹, Yu Jintian, Dinesh Sukamani², Manita Kusi¹

¹School of Management, Wuhan University of Technology,

²School of Civil Engineering and Architecture, Wuhan University of Technology,

Email: ashokshah3538@outlook.com, yjt8188@126.com,

dsukamani@gmail.com, manyatasth2@gmail.com

ABSTRACT

Research on environment management in construction industry is as topic of debate globally. Thus, this study examined how green transformational leadership played for green building sustainability via green creativity and green procurement. We developed an assimilated research model to examine the impact of green transformational leadership, green creativity and green procurement on sustainability in construction industry by accessing resources-based view theory and componential theory of creativity. The sample included from 305 project team member of construction firm in Nepal. Structural equation model (SEM) using SPSS 25.0 and AMOS 24.0 have been applied to find empirical results. The results revealed direct positive effects of green transformational leadership, green creativity and green procurement on sustainability. Green transformational leadership also appeared as predictor of green creativity and green procurement. Moreover, green creativity and green procurement found partial mediators of the relationship between green transformational leadership and sustainability in construction industry. Discussed future research direction along with theoretical implication and practical implication for environment policymakers and researcher attentive in promoting sustainability in construction industry.

Keywords: Sustainability, green building project, green leadership, construction industry

ACEITO EM: 08/03/2020

PUBLICADO: 30/11/2020



COMO A LIDERANÇA TRANSFORMACIONAL VERDE INFLUENCIA A SUSTENTABILIDADE? EFEITOS MEDIANTE DA CRIATIVIDADE VERDE E DA COMPRA VERDE

*How green transformational leadership influences sustainability?
Mediating effects of green creativity and green procurement*

Ashok Kumar Shah¹, Yu Jintian, Dinesh Sukamani², Manita Kusi¹

¹School of Management, Wuhan University of Technology,

²School of Civil Engineering and Architecture, Wuhan University of Technology,

Email: ashokshah3538@outlook.com, yjt8188@126.com,

dsukamani@gmail.com, manyatasth2@gmail.com

RESUMO

A pesquisa em gestão ambiental na indústria da construção é tema de debate global. Assim, este estudo examinou como a liderança transformacional ecológica desempenhou a sustentabilidade da construção ecológica por meio da criatividade ecológica e da aquisição ecológica. Desenvolvemos um modelo de pesquisa assimilado para examinar o impacto da liderança transformacional verde, da criatividade verde e da aquisição verde na sustentabilidade na indústria da construção, acessando a teoria da visão baseada em recursos e a teoria componencial da criatividade. A amostra incluiu 305 membros da equipe do projeto da empresa de construção no Nepal. Modelo de equação estrutural (SEM) usando SPSS 25.0 e AMOS 24.0 foi aplicado para encontrar resultados empíricos. Os resultados revelaram efeitos positivos diretos da liderança transformacional verde, criatividade verde e compras ecológicas na sustentabilidade. A liderança transformacional verde também apareceu como preditor de criatividade verde e compras verdes. Além disso, a criatividade verde e a aquisição verde encontraram mediadores parciais da relação entre liderança transformacional verde e sustentabilidade na indústria da construção. Discutimos a direção da pesquisa futura, juntamente com as implicações teóricas e práticas para os formuladores de políticas ambientais e pesquisadores que estejam atentos à promoção da sustentabilidade na indústria da construção.

Palavras-chave: Sustentabilidade, Projeto de construção verde, Liderança verde, Indústria da construção.

INTRODUCTION

The frequently change in world's climate, global warming grip on the planet and increasing pollution are concerned since 1970s but still unable to control this environmental degradation. National Aeronautics and Space Administration and National Oceanic and Atmospheric Administration revealed that the planet was hottest in the past decades and this movements happening due to human activities (NASA, 2020). The nature of human activities in construction industry also deserve for environment pollution because their decision impacts to construction materials handling and process (Cheriyana & Choi, 2020). The materials using in building construction such as tiles, concrete, chemicals and transports producing carbon dioxide and causing air pollution and water pollutions to the environment (Allen & Iano, 2019). So, organizational leaders are concerning this issue and concentrating making green strategies for sustainable future specially in the construction industry. Most of leaders are giving more priority on green building sustainability so that various climate changes and rapid increasing population and pollutions can control for sustainable development (Gou & Xie, 2017). Along with global concern, a developing country Nepal has also experienced with flood, earthquakes and untimely climate changes due to the environmental dilapidation. Hence, government has imposed to maintain the environment standards across in Nepal especially for construction industry. As a result, the organization are paying more attention to the green notion likes green leadership, green procurement, green innovation, green creativity and green building sustainability to protect environment (Bohari, Skitmore, Xia, & Teo, 2017; Chen & Chang, 2013).

In the context of green notion, some authors have argued that applying green strategy in business process would contribute in corporate social responsibility, which can increase their International Organization for Standardization (ISO 14000) series, market value, market image and market share (Chin, Tat, & Sulaiman, 2015; Jayashree, Malarvizhi, Kasim, & Mayel, 2016; J. Y. Yong, Yusliza, Ramayah, & Fawehinmi, 2019). Moreover, organization can have good competitive capabilities including positive green perception towards corporate society by applying green agenda (Mell, 2010).

Recently the literatures are increasing in Resources-based view (RBV) and componential creativity for green organizational performance. The RBV explains that if organization control the valuable, shortage, infrequent and non-substitutable resources, the firm can entertain with sustainable competitive advantage, which also affects by environmental factor (Das & Teng, 2000). RBV also consist that sustainable competitive advantage can be accomplished with the help of good leadership towards environmental problem. In pursuit of good leadership, green transformational leaders are carrying such green behaviors who motivate and inspire to the followers for achieving environment goal and keep continue effort beyond their capabilities for environment performance (Chen, Chang, & Lin, 2014). Moreover, Green transformational leadership (GTL) refers to bring new green creative idea and follow green process for sustainable development. With this instance, componential creativity explains that individual have own creativity influenced by work environment which reflect on sources of sustainable development (Amabile, 2012). For Instance, Mittal & Dhar (2016) revealed that GTL influence to green creativity of hotel staff which consists for reducing environment degradation. J. Liu, Liu, & Yang (2020) argued that green procurement supported by top-level managers are key component for implementation of environment practices. Therefore, firms can more strong in term of profitability and competitiveness if firm rich in resources-based view and creativity by leaders.

Despite the importance of green resources and creativity based leadership to the sustainability of construction firms most of studies examined other factors like social practice and performance, environment and economic performance, technology and business innovativeness and so on (Bamgbade, Kamaruddeen, & Nawi, 2017; Li, Ding, & Sun, 2019; Lu, Ye, Chau, & Flanagan, 2018). However, Pero, Moretto, Bottani, & Bigliardi (2017) argued that supply chain collaboration among parties needed for achieving sustainability in construction industry. Similarly, Tabassi et al. (2016) also discussed as intellectual competence of project managers signify to the sustainability in building industry. Thus, based on green resources to the sustainability have studied very few and so this study represents the analysis of green transformational leadership and which supportive factor can enhance to the sustainability in construction industry.

Thereby, this study has carried some place for contribution to the literature regarding green leadership and sustainability in construction industry. First, this study presents a new conceptual model that's links green leadership behavior of green building project members with sustainability. Independent variable (Green transformational leadership) and dependent variable (sustainability) of construction firm are the evidence for providing filling the literature gap. Secondly, this study carrying double theory namely, resources-based view theory and componential theory of creativity to describe the importance of green leadership behavior, green creativity, green procurement and sustainability in construction industry. Third, this study represent the resources and creativity based research, which explore influence of green leadership and sustainability in the construction industry. This is first attempt to analyses the factor of green leadership especially in construction firm. Fourth, this study examined the resources and creativity based of green leadership for sustainability in the perspective of developing country particularly in Nepal. After a big earthquake in 2015 in Nepal, this country is literally focused on green building projects. Finally, this study explores the green behavior and creativity of leaders because this investigate the direct and indirect relationship between GTL and sustainability in construction industry with the help of structural equation model.

1 THEORETICAL MODEL AND HYPOTHESIS DEVELOPMENT

1.1 Green Transformational leadership and sustainability

Transformational leadership deals with multidimensional concept like vision and goals, culture, structure, intellectual stimulation, individual support and performance expectation (Luyten & Bazo, 2019). Moreover, transformational leaders consist to the followers by encouraging self-motivate for achieving organizational goal and accomplish in synergetic way. With these behaviors, transformational leaders can develop new idea and innovation within the organization including inspiring to the team members to solve the problem in new ways (Waldman & Bass, 1991). According to resources-based view (RBV), the firm performance and competitive advantage subject to noticeable and non-noticeable resources (Das & Teng, 2000). Chang et al. (2018) also examined that perception of enterprises manager is non-noticeable which positively impact on sustainability in construction industry. Likewise, green transformation leadership is skill and technique resources that control the sustainability in construction industry. Green transformational leadership is defined as “behaviors of leaders who motivate followers to achieve environment goal and inspire followers to perform beyond expected levels of environment performance” (Chen & Chang, 2013). Thus, green transformational leadership play a significant role in the social, economic and environment traits of construction industry, which consist to sustainability (Afzal, Lim, & Prasad, 2017).

As mentioned by (Singh, Del Giudice, Chierici, & Graziano, 2020), green transformational leadership is important aspects that influence directly and indirectly on environment performance. Likewise, Zhou, Zhang, Lyu, & Zhang (2018) also explained in the field of management psychology that the green behavior of transformational leaders and product development performance are in positive relations with the degree of individual green value. Also not having green nature in leaders may cause in environment and sustainability (Dagiliūtė, Liobikienė, & Minelgaitė, 2018). Similarly, Mukonza & Swarts (2019) concluded that leaders with huge green oriented mindset towards the team are mostly promoting green organizational behavior. Furthermore, green transformational leadership is also examined as important for green supply chain as well as organization green value in the market (Khan, Jian, & Zhang, 2018; Teixeira, Jabbour, de Sousa Jabbour, Latan, & De Oliveira, 2016). Green transformational leaders are likely to leads to the followers and make them self-motivated to achieve the organization goal in greenly way that improvement their sustainability. Thus, we hypothesized as green transformational leadership is positively effect on sustainability.

Hypothesis 1. Green transformational leadership is positively related with sustainable development in construction development.

1.2 Green Creativity and sustainability

There are some studies examined that creativity and innovation requires for sustainability (Lim, 2016; Przychodzen, Przychodzen, & Lerner, 2016). Green creativity found as an important factor for sustainability in construction industry (Wao, 2018). Song & Yu (2018) showed that managers of organization who have comprehended green innovation results sustainable development and also helps for competitive advantage (Nunes, D., & de Hoyos Guevara, A. J., 2018). Likewise, Chen, Chang, Lin, Lai, & Wang (2016) argued that proactive and reactive innovation reacts green creativity, which influence to green product development performance. Thus, Green creativity relates the original ideas and novel for green product, green building, green process, green practices and sustainability (Chen & Chang, 2013). When an organization implements original useful green ideas, it encourages enhancing the green building and green innovation for society and environment. From the client and government point of view, they surely demand for less environment pollution and focusing on green building may forces to bring idea for green outcomes and process that fulfill their demand. According to stakeholder theory, the concern about environment are highly active by stakeholders in this age (Garvare & Johansson, 2010). Hence, firms have been focused on self-encourage to regulate the government environment plan. As per stakeholder forces, the managers are more focused on green creativity and innovation that help for economic, social and environmental concern, which turns into sustainability in construction industry. Therefore, based above discussion we propose the following hypothesis:

Hypothesis 2. Green creativity positively influences sustainable development in construction industry.

1.3 The links between GTL, GC and Sustainability

Despite the direct impact of green transformational leadership on sustainability in construction industry, the indirect impact of green transformation leadership on sustainability in construction industry through green creativity is explained by the componential theory of creativity. The componential theory of creativity state that “all humans with normal capacities are able to produces at least moderately creative work in some domain, some of the time and that the social environment (the environment) can influence both the level and the frequency of creative” (Amabile, 2012). Some authors argued that capabilities of managers which concern for creativity for their green outcomes. For instance, Mittal & Dhar (2016) argued that organizational green creativity depends on the four dimensions of transformational leaders because the leaders play a significant role for environmental performance with green behavior. Similarly, Chen & Chang (2013) revealed that the capabilities in green behavior and green leadership influence on green product development with the help of green creativity. Social, economic and environmental are the factor for sustainability which concern of leaders which play significant role for green building. Green transformational leadership is key to motivate followers and develop new idea and innovation during the challenging phase; good leadership capabilities able to meet industrial and environmental goals (Jia, Liu, Chin, & Hu, 2018). Hence, studies on sustainability in construction industry have habitually suggested that the organization need green leadership quality which lead the team in proper way that follower gives their huge effort for sustainable development. Therefore, we presume our third and fourth hypothesis:

Hypothesis 3. Green transformational leadership has positive effect on green creativity

Hypothesis 4. Green creativity mediates the relationship between green transformational leadership and sustainable development in construction industry.

1.4 Green Procurement and Sustainability

Procurements management and supply chain are two main factor in the construction industry for project success (Y. C. Yong & Mustafa, 2012). This means that the project managers of construction firm in the competitive market have to competently mange the procurement for run their project successfully. According to

green Council (2010) Green procurement is buying process of product and services which minimize the environment impact. Green procurement in construction industry catch all lifecycle which consist material extraction, supply chain process, manufacturing or producing, packing, storage and deliver on the construction site. Thus, Green procurement is an important factor in the new era for green transformation in the industry and contribute in economic and society greenly. The literature assumed that the green procurement under environment regulation reduce the environment impacts. For instance, Blome, Hollos, & Paulraj (2014) argued that firms have engaged in green procurement that reduced the impact on environment and increased in supplier performance. Selection of contractor and environment setting also considered while tender and evaluation criteria are also part of green procurement. This regulation can help stakeholder building materials with consist for less energy consumption, less carbon produces, less water pollution, waste management and minimize the environment pollution. Green procurement in construction industry improves the environment performance (Varnäs, Balfors, & Faith-Ell, 2009). Moreover, Chin et al. (2015) revealed that green supply chain considers green procurement that positive influenced on sustainability performance. Similarly, Braulio-Gonzalo & Bovea (2020) argued that green public procurement also helps to reduce the environmental impact from construction projects and sustainability occurs. Hence, based on above argument we hypothesized as:

Hypothesis 5. Green procurement is positively influenced to sustainable development in construction industry.

1.5 The Links between GTL, GP and Sustainability

The indirect effect of green transformational leadership on sustainable development in construction industry through green procurement can be explain by natural resources-based view theory (NRBV). This theory is related with green supply chain management and part of resources-based view (RBV) Sarkis, Zhu, & Lai (2011) that explain if firms have rare, scares, valuable and non-substitute resource that can enhance the competitive advantage (Barney, 1991). In other words, NRBV contemplate a good supervision for environment concern which reflects to firms competitive advantage. The growing literature on green transformational leadership comprises limited research on relationship between green transformational leadership and green procurement. Green procurement can be defined as the buying product and services which cause minimize effects on environment. In other words, all the activities in supply chain process concern for the healthy and protect environment (J. Liu et al., 2020). Blome, Foerstl, & Schleper (2017) noted that green procurement is impact by two leadership style and incentives. Green transformational leaders have green perception towards team including procurement team, therefore green leaders influence to maintain green procurement system for environment sustainability.

Green behavior of transformational leaders arise with green procurement may contribute to the business competitiveness and increase the market value and make good performance. For instance, Bag (2017) found that role of green procurement and sustainability in supplier networks are in positive relations. Kura (2016) also examined that green leadership and green behavior at work are in positive relationship. Singh et al. (2020) suggested that how green human resources interact with green transformational leadership for environment performance. Green leadership would make easier for firm to take advantage in the market which can do competition in the construction industry because green leaders have ability to handle the followers for green environment and have good green procurement in the supply chain process which minimize air, water and sound pollution. Moreover, green transformational leadership may influence to the strategic plan which occurs green system (L. Liu & Zhao, 2019). In construction industry with green leadership are more to likely to associates in green procurement which enhance sustainability. Hence, our hypothesis as:

Hypothesis 6. Green transformational leadership has positive impact on green procurement.

Hypothesis 7. Green procurement mediates the relationship between green transformational leadership and sustainability in construction industry.

Figure 1: Conceptual Model

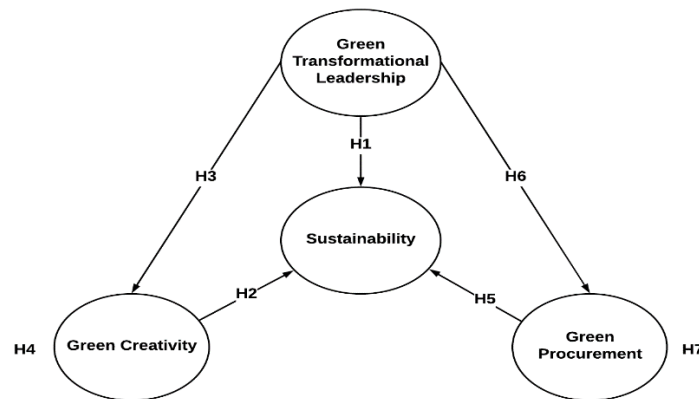

2 RESEARCH DESIGN AND METHOD

The population of this research covered from construction sector of Nepal. In this survey, we used self-administrative and deductive reasoning method to analyze relationship between variables. We collected the cross-sectional data form A class construction firm who contribute to the green building and environment protection. The construction industry has selected to do survey because it contributes for develop the nation, generating huge employment and economic stability. Moreover, this industry includes the factor for minimize the environment pollution and appraise for sustainability (Freitag, Quelhas, França, & Meiriño, 2020; Silva, Rincón-González, & Diez-Silva, 2020).

2.1 Sample design and Data collection

The construction firm in Nepal mostly located in Kathmandu valley but the project run by diffract construction company are spread all over in the Nepal. After getting the details of construction project, we have visited their offices and project sites along with we did telephonic call. The data was collected by questionnaire method. We distributed more than 350 questionnaires to the project team members and also sent some questionnaire attachments via email. We received 318 questionnaire form the project team member and we excluded 13 due to missing and inappropriate data. Hence, we use total 305 data for final survey.

2.2 Participant's information

The total responds for the demographic data was 305 and which was more than 200 responded for structural equation model (Kelloway, 1998). Form the total respondents in term of team size in construction project 18(5.9%) were below 20 team size, 130(42.62%) were between 21 and 30 team size, 92(30.16%) were between 31 and 40 team size and 65(21.31%) were above 40 team size. Similarly, in terms of type of project, 31(10.16%) were infrastructure type of project, 23(7.54%) form industrial, 169(55.41%) from building projects, 54(17.70%) were from transportation projects and 28(9.18%) from water structure like hydro power projects. Table 1 shown demographic data in details:

Table 1: Demographics data

	Frequency	Percentage		Frequency	Percentage
Team Size			Experience		
0-10	0	0.00%	1 -5 Years	85	27.87%
11-20	18	5.90%	6-10 Years	86	28.20%
21-30	130	42.62%	11-15 Years	62	20.33%
31-40	92	30.16%	16-20 Years	46	15.08%
40- Above	65	21.31%	20-Above	26	8.52%
Type of project			AGE		
Infrastructure	31	10.16%	o-20 Years	0	0.00%
Industrial	23	7.54%	21-30 Years	108	35.41%
Building	169	55.41%	31-40 Years	92	30.16%
Transportation	54	17.70%	41-50 Years	78	25.57%
Water Structure	28	9.18%	50-above	27	8.85%

2.3 Variables measurement

We used the questionnaire for this survey which was already conducted for research previously. All the questionnaire was measured in five point Likert scale (1=strongly disagree, and 5= strong agree). The variable green transformational leadership have adopted the measures of Mittal & Dhar (2016) who had six measurement constructs. With regard to green creativity, we adopted the measures again from Mittal and Dhar with six measuring items. The measurement of green procurement, we adopted the measures from Wong, San Chan, & Wadu (2016). There were thirty-five measurement item of green procurement for Hong Kong's construction industry but we only adopt six measures as per expert guidance and suit for Nepalese construction industry. For the sustainability measurement, we adopted from Sharma (2018) where she used six item for measure the sustainability development. This study used control variable as well for better results. The project type and the size of team member were directly considered in the model.

3 RESULTS

3.1 Preliminary Analysis

The collected data have confirmed with calculating skewness for normal distribution and all the skewed value were between +1 to -1 (Curran, West, & Finch, 1996) and then confirmed with linearity for the data ($p=0.00$). The value of Durbin-Watson was close to 2 which means that the research data was uncorrelated (Field, 2013). For the reliability and consistent of data, we calculated Cronbach's Alpha and all the value were greater than 0.7 (Green transformational leadership: $\alpha=0.87$; Green creativity: $\alpha= 0.89$; Green Procurement: $\alpha= 0.91$ and Sustainability: $\alpha= 0.90$). we measured the KMO (Kaiser-Meyer-Olkin) value ($KMO=0.917$) for confirm the sample adequacy of variable and the value were above 0.6 which confirmed it is supported (Kaiser & Rice, 1974).

3.2 Common Method Bias (CMB) and Multicollinearity

While data collection, there may chance of common Method Bias (CMB) due to same sources which may a problem for this study. Hence, we calculated Harmon’s one factor test for confirm CMB with the help of SPSS. We got the value only 34.87% which was less than threshold 50% (Ekstrom, Dermen, & Harman, 1976). For the multicollinearity, we calculated variance Inflation factors (VIF) and the score was less than 3 hence the data was free form muliticollinearity issue (J. Hair, Anderson, Babin, & Black, 2010).

3.3 Model Evaluation

In this study, we used structural equation model (SEM) which considered for accurate result of estimated integrated model (Ullman & Bentler, 2003; Yi, Uddin, Das, Mahmood, & Soheli, 2019). The SEM is mostly uses in management science field. In the SEM, we used AMOS 24.0 and SPSS 25.0 to test the measurement model and structural model. Moreover, bootstrapping 5000 also used for examine the relationship.

3.4 Measurement Model Evaluation

The measurement model was tested for confirm whether constructs were suitable for variable or not. Therefore, we tested confirmatory factor analysis (CFA), reliability test and validity for suitability concern. The model reflects better model fit which was acceptable [CMIN/DF= 1.481, RMSEA = 0.040, GFI= 0.914, RMR= 0.016, TLI= 0.970, CFI=0.973] which were under the standard rage (Harrington, 2009; Thompson, 2004). We also tested the reliability, convergent validity and discriminant validity which shown in Table 2. The threshold value for reliability and convergent validity are: CR>0.7, CR>AVE and AVE>0.5(J. Hair et al., 2010). Moreover, all value of composite reliability (CR) values was above standard value 0.7. Also all the value of CR was greater than AVE value and AVE value was greater than 0.5. Hence, it was confirmed for internally consistent. Discriminant validity deals with degree of difference between constructs (Joseph F Hair, William C Black, Barry J Babin, Rolph E Anderson, & Ronald L Tatham, 2006b). The standard value for discriminant validity is MSV<AVE and squire root of AVE should be greater than construct correlation (Joseph F Hair, William C Black, Barry J Babin, Rolph E Anderson, & Ronald L Tatham, 2006a). And, our outcomes of discriminant validity match with standard value. Figure 2 shows the CFA analysis with their estimated loading.

Table 2: CR, AVE, MSV, Correlation Metrix and Discriminant Validity

	CR	AVE	MSV	GC	GTL	SUS	GP
Green Creativity	0.900	0.601	0.377	0.775			
Green Transformational Leadership	0.867	0.521	0.377	0.614	0.722		
Sustainability	0.900	0.600	0.276	0.460	0.525	0.774	
Green Procurement	0.916	0.648	0.193	0.389	0.430	0.439	0.805
Mean				4.282	3.870	3.978	3.402
Standard Deviation				0.594	0.448	0.471	0.495
Cronbach's				0.899	0.867	0.900	0.919
KMO				0.888	0.89	0.900	0.874

Note: Diagonal bold value represents squire root of AVE. CR, Construct Reliability; AVE, Average Variance Extracted; MSV, Maximum Shared Value; GC, Green Creativity; GTL, Green Transformational Leadership; SUS, Sustainability; GP, Green Procurement.

Figure 2: Confirmatory Factor Analysis

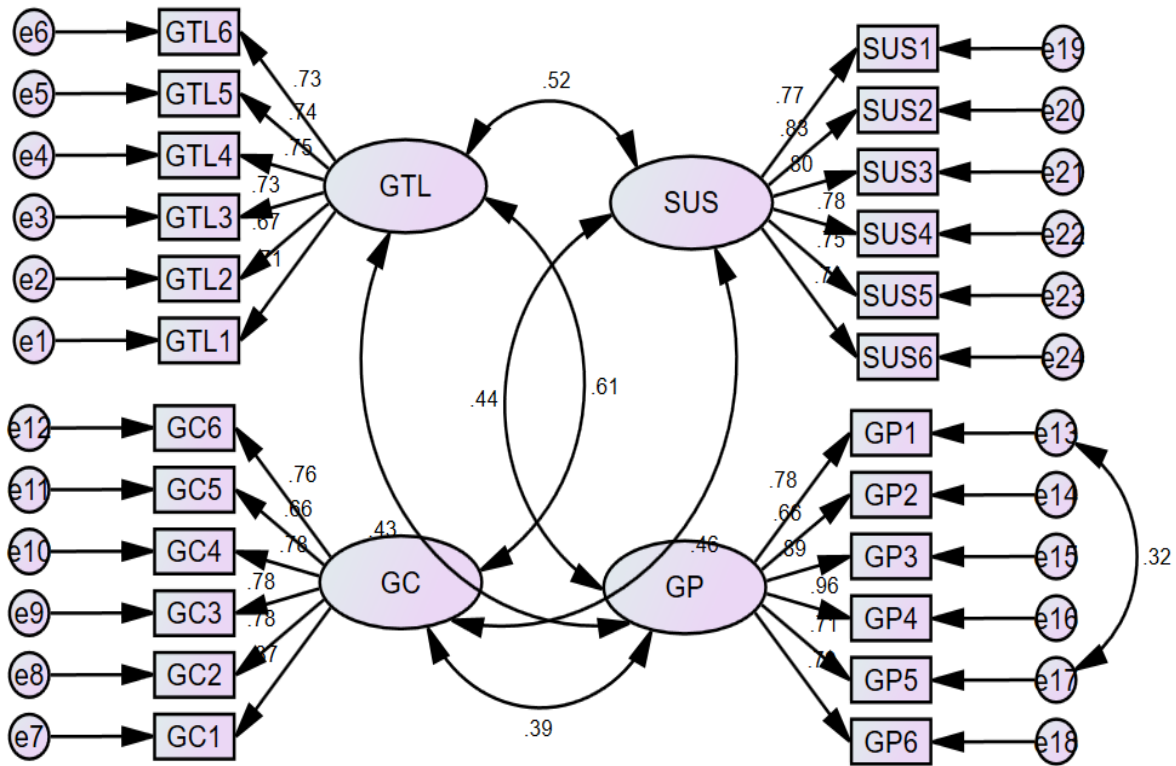

3.5 Structural model and Hypothesis Testing

We implemented AMOS.24 under SEM to test the direct and indirect hypothesis. For the direct hypothesis, we tested the relationship between green transformational leadership and sustainability, green creativity and green procurement, and between construction industry’s sustainability and their green procurement and green creativity. For the indirect hypothesis, we used two tactics to find the impact of green transformational leadership on sustainability with green procurement and green creativity as mediating. Thus, our study was multiple mediation model. As per Cheung & Lau (2008), we used bootstrap approach with number of bootstrap sample 5000 and 95% confidence interval level to test direct impact, total indirect impact, total impact and indirect impact of structural model by using AMOS 24. However, we had good estimated model fit [CMIN/DF=1.63, $p=0.00$; RMR=0.057; GFI=0.901; TLI= 0.956; CFI=0.961; RMSEA= 0.045] which covers the threshold value (J. F. Hair et al., 2006a; Hooper, Coughlan, & Mullen, 2008; Krajangsri & Pongpeng, 2017). We also found the β -coefficient (Estimates), Significance level (p-value) and R^2 (Squared Multiple Correlation) for genuine results. According to Hair Jr, Hult, Ringle, & Sarstedt (2016), the value of square multiple correlation in acceptable in social science if it is greater than 0.20 (i.e. $R^2_{GP}= 0.253$; $R^2_{GC}= 0.361$; $R^2_{SUS}= 0.331$). Hence, together green transformational leadership, green procurement, green creativity explained 33.1% of variation in sustainability, 25% and 36% explained green procurement and green creativity respectively.

Figure 3: Structural Model

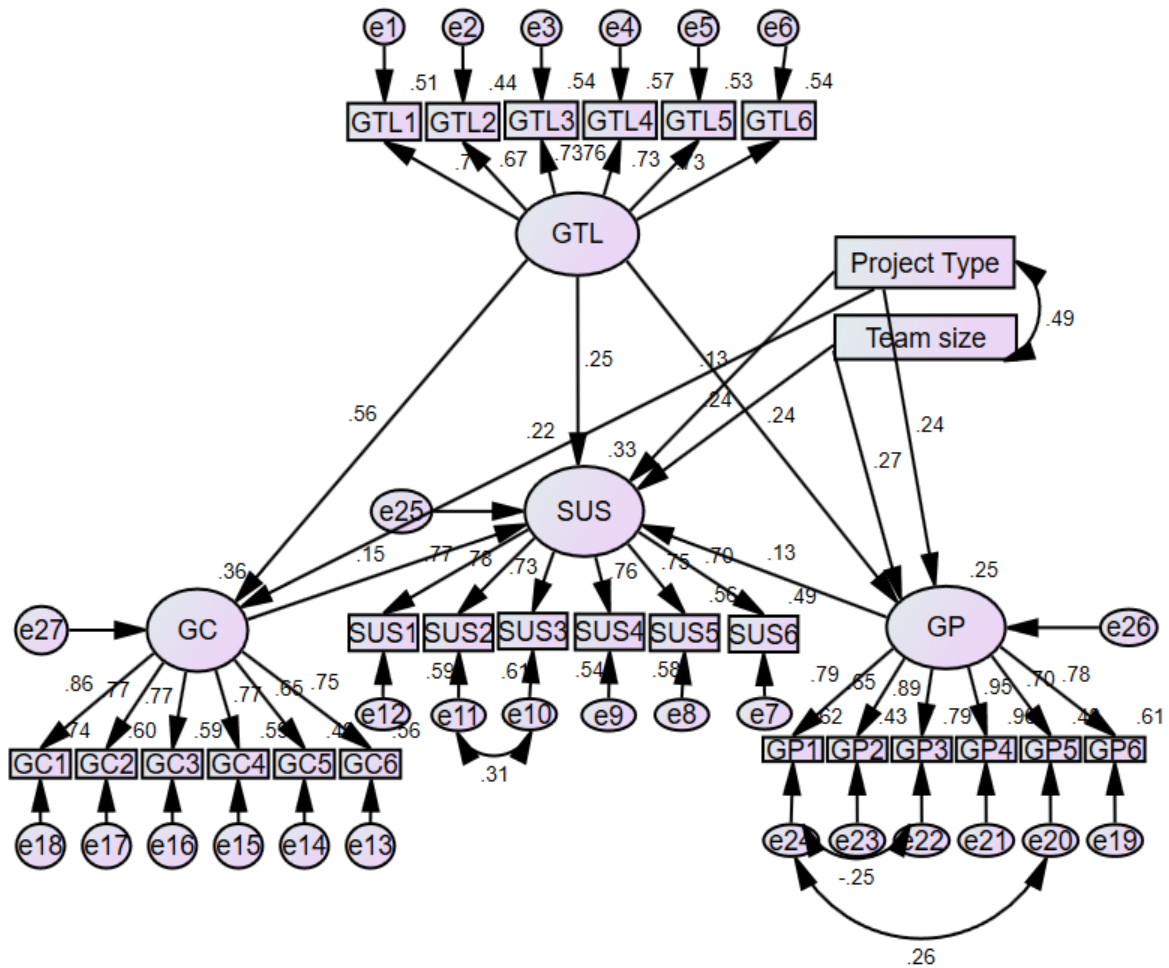

We tested five direct hypotheses and two indirect hypotheses. For Direct Hypothesis, the result show that green transformational leadership had direct impact on sustainability ($\beta=0.254$, $p<0.05$). Moreover, the total effect of green transformational leadership in sustainability was 0.32 ($p<0.001$). Hence, our first hypothesis was green transformational leadership is positively influence to the sustainability in construction industry so Hypothesis 1 was accepted. Similarly, there was impact of green creativity on sustainability ($\beta= 0.153$, $p<0.05$) and green procurement on sustainability ($\beta= 0.131$, $p<0.05$). Therefore, as per we conducted hypothesis 2 and 5 also accepted. There was also direct influence of green transformational leadership on green creativity ($\beta=0.559$, $p<0.001$) and green procurement ($\beta=0.244$, $p<0.001$). Hence, our third and sixth hypothesis was also accepted. Table 3 shown the details of direct effects.

Table 3: Direct effects in structural model.

Hypothesis	Path Relation	Estimate	SE	CR	p	Decision
H1	SUS <--- GTL	0.254	0.066	3.302	0.004	Supported
H2	SUS <--- GC	0.153	0.06	2.082	0.042	Supported
H3	GC <--- GTL	0.559	0.074	8.035	0.000	Supported
H5	SUS <--- GP	0.131	0.053	2.059	0.026	Supported
H6	GP <--- GTL	0.244	0.06	4.211	0.000	Supported

Remaining hypothesis 4 and 7 was indirect hypothesis. Hypothesis 4 was as the green creativity play mediator role between green transformational leadership and sustainability in construction industry. We found that green creativity had indirect affect ($\beta= 0.08, p<0.05$). Similarly, hypothesis 5 was as the green procurement play mediator role between green transformational leadership and sustainability in construction industry and the result show that green procurement had indirect effect ($\beta=0.03, p<0.05$). Without multiple mediation on effect of green transformation leadership on sustainability in construction industry was significant ($\beta=0.526, p<0.001$). Thereafter, we considered both green creativity and green procurement as mediator in the model with the help of AMOS bootstrap. The direct influence of green transformational leadership on sustainability was reduced with significant. Hence, our result confirmed that green procurement and green creativity was partially mediated in relationship between green transformational leadership and sustainability in construction industry. Thus, Hypothesis 4 and 7 were partially accepted. Table 4 shown the details of indirect effect.

Table 4: indirect effects in structural model.

Hypothesis	Path	Estimate	SE	p	Decision
H4	GTL-->GC-->SUS	0.08	0.038	0.035	Partial Supported
H7	GTL-->GP-->SUS	0.03	0.015	0.018	Partial Supported

4 DISCUSSION AND CONCLUSION

The main aim of this study to examine the influence of green transformational leadership on sustainability in the field of construction industry with influence of green creativity and green procurement as multiple mediation. Using SEM, AMOS, we conceptualized a model and quantify the direct and indirect influence of green transformational leadership on sustainability with the help of theoretical underpinning like componential theory of creativity and resources-based view theory. Additionally, we developed seven hypotheses to test the model from literature review and theoretical observation. The result of all seven hypotheses test was positive significance.

The first hypothesis (H1) has formulated as positive influence of green transformational leadership on sustainability which consistent with the result of (Singh et al., 2020). Who revealed that the role of green transformational leadership positive influenced on environment performance. Chen et al. (2014) also found that green transformational leadership had direct positive impact on green performance. We found that sustainable practice and managers' leadership relate with green transformation leadership which consistent with Pham & Kim (2019) and Danquah, J. A., Duah, D., & Marful, A. B. (2017) who found that sustainable practice and manager's leadership positive influence on sustainability in construction firms. Our results also congruent with. Tabassi et al. (2016), who found that leadership competency has positive effect on sustainable construction development. Hence, our results suggest that transformational leaders with green behavior impact to sustainability in construction firm.

Generally, sustainability is lacking without creativity and innovation. we found as green creativity has positive assist with sustainability in construction firm is our second hypothesis (H2), which consistent with the result of Fields & Atiku (2019), who argued that collective green creativity and eco-innovation positive impacts on sustainable business solution in any organization. Moreover, our finding also consistent with the result of Chen & Chang (2013) and Chen et al. (2016), who revealed that green creativity was positively influence for green performance. Based on above literature it can assume that construction industry also need green creativity for sustainable development. Similarly, the hypothesis five (H5) assumed as green procurement positively influence to sustainability which is consistent with the result of Bohari et al. (2017), who argued that green procurement positively impacts to the green performance in environment, financial and social subjective indicators in construction firms. Moreover, Adham & Siwar (2012) and Bag (2017) also revealed that green procurement in the construction sector play important role for protect the environment. Sanchez, Lehtiranta,

Hampson, & Kenley (2014) and Zeppel (2014) also studied that green procurement is essential elements for sustainability in construction industry. Hence, our result also revealed with above literature that green procurement is an important factor for sustainability.

The influence of green transformational leadership on green creativity (H3) and on green procurement (H6) has not more literature in construction industry so we tried to fulfill the gap by this study. For hypothesis three, we found that green transformation leadership affect green creativity, which is consistent with the result of Mittal & Dhar (2016), who discussed that green transformational leadership positively impact to green creativity. According to Singh et al. (2020) and Bahzar (2019), green transformational leadership was positive effect on green creativity due to green nature of leaders. In this context, H3 is acceptance for our study which consist that green leadership might be more relevant to green creativity. For hypothesis six, we found that green transformational leadership influence to the green procurement, which is consistent with the result of Blome et al. (2017), who studied that leaders with green perception give positive impact to the green supplier. Furthermore, we found that green procurement is important for construction firm and an organization need greenly behavior attitude for green supply chain management (J. Liu et al., 2020). With this scenario the sixth hypothesis support that green transformational leadership must influence to sustainability.

We found that green creativity and green procurement partially mediated between green transformational leadership and sustainability in construction industry. Hence, our fourth and seventh hypothesis (H4 and H7) partial mediation supported. Green creativity mediates the relationship between green transformational leadership and sustainability development with the help of componential theory of creativity. This theory suggest that human behavior might improves sustainability by creativity and innovation (Bahzar, 2019). Green transformational leadership enable the creativity for sustainable development. Our results corroborate with Chen & Chang (2013) who argued that green transformational leadership influence green creativity and green performance for product development. Moreover, our finding also consistent with the result Chen et al. (2014), who revealed that green transformational leadership affect green performance via green mindfulness. We indicate that green mindfulness belongs with mind creativity and green perception of leader use creativity mind for sustainability. In other hand, green procurement mediates the relationship between green transformational leadership and sustainability in construction industry which consist with resources-based theory. Green leadership might influence green supply chain, material handling, and product development and enhance the sustainability in construction sector (Chin et al., 2015; Thomson & Jackson, 2007). Therefore, green transformational leadership is vital for sustainability development. The direct and also indirect affects through green creativity and green procurement to sustainability. Thus, our study of the relationship between green transformational leadership and green creativity, green procurement which can enhance sustainability in construction industry.

4.1 Theoretical Contribution

This study adding to advancing the resource-based and empirical mark in the literature of sustainable regarding construction environment protection from structural relationship between green transformational leadership, green creativity, green procurement and sustainability development in construction firms. Green leadership supports sustainable development in construction forms via green creativity and green procurement by using multiple concepts and theories. We bridge the gap in contextualized information on green transformational leadership by exploring the precursors of sustainability from sample of developing country Nepal in construction firms. Moreover, our finding reliability and previous research specifies that green transformational leadership is universal concept. A research on green leadership in construction firms using SEM also contributes to the literature and helps to fulfill the methodological gap. Furthermore, earlier studies only deliberate the linear relationship between green transformational leadership and sustainable development and leaving a gap in resource and creativity for indirect influence of green transformational leadership on sustainable development in construction firms. Hence, we bridged the gap and developed multi-mediator structural equation model to test the hypothesis for indirect relations. Moreover, this is the first attempt for green transformational leadership and sustainable development in construction firms in Nepal using SEM.

In conclusion, the indirect relations between green creativity and green procurement partially mediate the relationship between green transformational leadership and sustainable development in construction firms, adding two more ways to linking green leadership and sustainability.

4.2 Managerial Contribution

The finding of this study provides for project managers or who interested for sustainable development of construction firms which keen to encouraging for environmental behavior. Firstly, the green transformational leadership behavior impacts on employee's green creativity and green perception in procurement function and thereby ensures sustainability in construction firms. Green construction management can play a crucial role for emerging sustainable green building by adopting green transformational leadership. Accordingly, construction project managers should focus on environment policies, environmental training program to the followers and daily motivate for reducing environment pollution. Secondly, leader's green creativity also plays a crucial role for sustainability in construction firm. Therefore, managers should develop the necessarily skill and knowledge themselves and their team members for green creativity which enhance sustainability. Managers of construction firm could advise to focus on promoting new ideas to achieve environmental goals. Thirdly, green procurement also plays a vital role for sustainability in construction firm. As procurement department in construction industry could be greater impacts on green building projects, managers should try to recommend using non-toxic material on construction sites. Managers could advise to adopt waste management, green technology and follow the environment regulations. Lastly, construction managers must emphasis to use less paper, proper use of electricity, water management etc. and further improve green behaviors to enhance sustainability.

4.3 Limitation and Future direction

This study carrying various contribution although has some limitations which need to be discuss. First, the study conducted based on construction industry of Nepal, there is necessarily to do study in other industry as well such as banking sector, automobiles industry and hospitability in the future. Second, this study used cross-sectional design which is another limitation, thus future research likely to use interview or longitudinal data research. Third, this study has only two possible mediators between green transformational leadership and sustainability. The mediators, green creativity and green procurement only partial mediated which recommend that there would be another mediation the relationship between green transformational leadership and sustainability. Furthermore, future studies can be including more variable which are not included in this study like organizational culture, green capabilities.

CONCLUSION

This study revealed that the role of green transformational leadership positively direct influence to sustainability and indirect influence through green creativity and green procurement to sustainability in the construction industry. This empirical research used multi theory to develop research model from 305 sample of Nepalese construction via structured questionnaire. We used SPSS and AMOS to test our hypothesis and the result shows that green transformational leadership, green creativity and green procurement directly affects sustainable development in construction industry, whereas green creativity and green procurement play partially mediate the relationship between green transformational leadership and sustainability. Thus, we considered that green transformational leadership play as vital role for green creativity, green procurement and sustainability in construction industry.

REFERENCES

- ADHAM, K., & SIWAR, C. Empirical investigation of government green procurement (GGP) practices in Malaysia. *OIDA international journal of sustainable development*, 4(4), 77-88, 2012.
- AFZAL, F., LIM, B., & PRASAD, D. An investigation of corporate approaches to sustainability in the construction industry. *Procedia Engineering*, 180, 202-210, 2017.
- ALLEN, E., & IANO, J. *Fundamentals of building construction: materials and methods*: John Wiley & Sons, 2019.
- AMABILE, T. M. Componential theory of creativity. *Harvard Business School*, 12(96), 1-10, 2012.
- BAG, S. Role of Green Procurement in Driving Sustainable Innovation in Supplier Networks: Some Exploratory Empirical Results. *Jindal Journal of Business Research*, 6(2), 155-170, 2017.
- BAHZAR, M. Effects of Green Transformational and Ethical Leadership on Green Creativity, Eco-Innovation and Energy Efficiency in Higher Education Sector of Indonesia. *International Journal of Energy Economics and Policy*, 9(6), 408-414, 2019.
- BAMGBADE, J. A., KAMARUDDEEN, A. M., & NAWI, M. Malaysian construction firms' social sustainability via organizational innovativeness and government support: The mediating role of market culture. *Journal of Cleaner Production*, 154, 114-124, 2017.
- BARNEY, J. Firm resources and sustained competitive advantage. *Journal of management*, 17(1), 99-120, 1991.
- BLOME, C., FOERSTL, K., & SCHLEPER, M. C. Antecedents of green supplier championing and greenwashing: An empirical study on leadership and ethical incentives. *Journal of Cleaner Production*, 152, 339-350, 2017.
- BLOME, C., HOLLOS, D., & PAULRAJ, A. Green procurement and green supplier development: antecedents and effects on supplier performance. *International Journal of Production Research*, 52(1), 32-49, 2014.
- BOHARI, A. A. M., SKITMORE, M., XIA, B., & TEO, M. Green oriented procurement for building projects: Preliminary findings from Malaysia. *Journal of Cleaner Production*, 148, 690-700, 2017.
- BRAULIO-GONZALO, M., & BOVEA, M. D. Relationship between green public procurement criteria and sustainability assessment tools applied to office buildings. *Environmental Impact Assessment Review*, 81, 106310, 2020.
- CHANG, R.-D., ZUO, J., ZHAO, Z.-Y., SOEBARTO, V., LU, Y., ZILLANTE, G., & GAN, X.-L. Sustainability attitude and performance of construction enterprises: A China study. *Journal of Cleaner Production*, 172, 1440-1451, 2018.
- CHEN, Y.-S., & CHANG, C.-H. The determinants of green product development performance: Green dynamic capabilities, green transformational leadership, and green creativity. *Journal of Business Ethics*, 116(1), 107-119, 2013.
- CHEN, Y.-S., CHANG, C.-H., & LIN, Y.-H. Green Transformational leadership and green performance: The mediation effects of green mindfulness and green self-efficacy. *Sustainability*, 6(10), 6604-6621, 2014.

- CHEN, Y.-S., CHANG, T.-W., LIN, C.-Y., LAI, P.-Y., & WANG, K.-H. The influence of proactive green innovation and reactive green innovation on green product development performance: The mediation role of green creativity. *Sustainability*, 8(10), 966, 2016.
- CHERIYAN, D., & CHOI, J.-H. A review of research on particulate matter pollution in the construction industry. *Journal of Cleaner Production*, 120077, 2020.
- CHEUNG, G. W., & LAU, R. S. Testing mediation and suppression effects of latent variables: Bootstrapping with structural equation models. *Organizational research methods*, 11(2), 296-325, 2008.
- CHIN, T. A., TAT, H. H., & SULAIMAN, Z. Green supply chain management, environmental collaboration and sustainability performance. *Procedia Cirp*, 26, 695-699, 2015.
- COUNCIL, G. Report of the research study on the current status and direction for green purchasing in Hong Kong. Green Council, 2010.
- CURRAN, P. J., WEST, S. G., & FINCH, J. F. The robustness of test statistics to nonnormality and specification error in confirmatory factor analysis. *Psychological methods*, 1(1), 16, 1996.
- DAGILIŪTĖ, R., LIOBIKIENĖ, G., & MINELGAITĖ, A. Sustainability at universities: students' perceptions from green and non-green universities. *Journal of Cleaner Production*, 181, 473-482, 2018.
- DAS, T. K., & TENG, B.-S. A resource-based theory of strategic alliances. *Journal of management*, 26(1), 31-61, 2000.
- DANQUAH, J. A., DUAH, D., & MARFUL, A. B. SUSTAINABLE PRACTICES IN REAL ESTATE HOUSING IN GHANA: PERCEPTION OF OCCUPANTS. *Journal on Innovation and Sustainability*. RISUS, ISSN 2179-3565, 8(4), 98-113, 2017.
- EKSTROM, R. B., Dermen, D., & Harman, H. H. Manual for kit of factor-referenced cognitive tests (Vol. 102), Educational testing service Princeton, NJ, 1976.
- FIELD, A. *Discovering statistics using IBM SPSS statistics*: sage, 2013.
- FIELDS, Z., & ATIKU, S. O. Collective Green Creativity and Eco-Innovation as Key Drivers of Sustainable Business Solutions in Organizations *Green Business: Concepts, Methodologies, Tools, and Applications* (pp. 415-439), IGI Global, 2019.
- FREITAG, A. E. B., QUELHAS, O. L., FRANÇA, S. L. B., & MEIRIÑO, M. J. Implementation of Lean Management: Sustainability in the Construction Industry: The Case of Brazilian Companies *New Approaches to CSR, Sustainability and Accountability, Volume I* (pp. 25-44), Springer, 2020.
- GARVARE, R., & JOHANSSON, P. Management for sustainability—a stakeholder theory. *Total quality management*, 21(7), 737-744, 2010.
- GOU, Z., & XIE, X. Evolving green building: triple bottom line or regenerative design? *Journal of Cleaner Production*, 153, 600-607, 2017.
- HAIR, J., ANDERSON, R., BABIN, B., & BLACK, W. *Multivariate data analysis: A global perspective* (Vol. 7), Pearson Upper Saddle River: NJ, 2010.

- HAIR, J. F., BLACK, W. C., BABIN, B. J., ANDERSON, R. E., & TATHAM, R. L. Multivariate data analysis 6th Edition. Pearson Prentice Hall. New Jersey. humans: Critique and reformulation. *Journal of Abnormal Psychology*, 87, 49-74, 2006a.
- HAIR, J. F., BLACK, W. C., BABIN, B. J., ANDERSON, R. E., & TATHAM, R. L. Multivariate data analysis (Vol. 6), Upper Saddle River, NJ: Pearson Prentice Hall, 2006b.
- HAIR JR, J. F., HULT, G. T. M., RINGLE, C., & SARSTEDT, M. A primer on partial least squares structural equation modeling (PLS-SEM), Sage publications, 2016.
- HARRINGTON, D. Confirmatory factor analysis: Oxford university press, 2009.
- HOOPER, D., COUGHLAN, J., & MULLEN, M. Structural equation modelling: Guidelines for determining model fit. *Articles*, 2, 2008.
- JAYASHREE, S., MALARVIZHI, C. A., KASIM, A., & MAYEL, S. Impact of external factors on implementation of ISO 14000 EMS towards corporate sustainability. *International Information Institute (Tokyo). Information*, 19(7A), 2631, 2016.
- JIA, J., LIU, H., CHIN, T., & HU, D. The continuous mediating effects of GHRM on employees' green passion via transformational leadership and green creativity. *Sustainability*, 10(9), 3237, 2018.
- KAISER, H. F., & RICE, J. Little jiffy, mark IV. *Educational and psychological measurement*, 34(1), 111-117, 1974.
- KELLOWAY, E. K. Using LISREL for structural equation modeling: A researcher's guide: Sage, 1998.
- KHAN, S. A. R., JIAN, C., & ZHANG, Y. The Role of Ethical Leadership in brand image building and cost reduction through the adoption of green practices: A Path Analysis Using SEM. Paper presented at the 2018 2nd International Conference on Data Science and Business Analytics (ICDSBA), 2018.
- KRAJANGSRI, T., & PONGPENG, J. Effect of sustainable infrastructure assessments on construction project success using structural equation modeling. *Journal of Management in Engineering*, 33(3), 04016056, 2017.
- KURA, K. M. Linking environmentally specific transformational leadership and environmental concern to green behaviour at work. *Global Business Review*, 17(3_suppl), 1S-14S, 2016.
- LI, Y., DING, R., & SUN, T. The Drivers and Performance of Environmental Practices in the Chinese Construction Industry. *Sustainability*, 11(3), 614, 2019.
- LIM, W. M. Creativity and sustainability in hospitality and tourism. *Tourism Management Perspectives*, 18, 161-167, 2016.
- LIU, J., LIU, Y., & YANG, L. Uncovering the influence mechanism between top management support and green procurement: The effect of green training. *Journal of Cleaner Production*, 251, 119674, 2020.
- LIU, L., & ZHAO, L. The Influence of Ethical Leadership and Green Organizational Identity on Employees' Green Innovation Behavior: The Moderating Effect of Strategic Flexibility. Paper presented at the IOP Conference Series: Earth and Environmental Science, 2019.

- LU, W., YE, M., CHAU, K., & FLANAGAN, R. The paradoxical nexus between corporate social responsibility and sustainable financial performance: Evidence from the international construction business. *Corporate Social Responsibility and Environmental Management*, 25(5), 844-852, 2018.
- LUYTEN, H., & BAZO, M. Transformational leadership, professional learning communities, teacher learning and learner centred teaching practices; Evidence on their interrelations in Mozambican primary education. *Studies in educational evaluation*, 60, 14-31, 2019.
- MELL, I. C. Green infrastructure: concepts, perceptions and its use in spatial planning. Newcastle University, 2010.
- MITTAL, S., & DHAR, R. L. Effect of green transformational leadership on green creativity: A study of tourist hotels. *Tourism Management*, 57, 118-127, 2016.
- MUKONZA, C., & SWARTS, I. Examining the Role of Green Transformational Leadership on Promoting Green Organizational Behavior Contemporary Multicultural Orientations and Practices for Global Leadership (pp. 200-224), IGI Global, 2019.
- NASA, N. NASA, NOAA Analyses Reveal 2019 Second Warmest Year on Record, 2020.
- NUNES, D., & DE HOYOS GUEVARA, A. J. Sustainable Leadership: A Search for Better Results from Interactions. *Journal on Innovation and Sustainability*, 9(2), 47-54, 2018.
- PERO, M., MORETTO, A., BOTTANI, E., & BIGLIARDI, B. Environmental collaboration for sustainability in the construction industry: An exploratory study in Italy. *Sustainability*, 9(1), 125, 2017.
- PHAM, H., & KIM, S.-Y. The effects of sustainable practices and managers' leadership competences on sustainability performance of construction firms. *Sustainable Production and Consumption*, 20, 1-14, 2019.
- PRZYCHODZEN, W., PRZYCHODZEN, J., & LERNER, D. A. Critical factors for transforming creativity into sustainability. *Journal of Cleaner Production*, 135, 1514-1523, 2016.
- SANCHEZ, A. X., LEHTIRANTA, L., HAMPSON, K. D., & KENLEY, R. Evaluation framework for green procurement in road construction. *Smart and Sustainable Built Environment*, 2014.
- SARKIS, J., ZHU, Q., & LAI, K.-h. An organizational theoretic review of green supply chain management literature. *International journal of production economics*, 130(1), 1-15, 2011.
- SHARMA, M. Development of a 'Green building sustainability model' for Green buildings in India. *Journal of Cleaner Production*, 190, 538-551, 2018.
- SILVA, H. F. C., RINCÓN-GONZÁLEZ, C. H., & DIEZ-SILVA, H. M. Sustainability on Project Management: An Analysis of the Construction Industry in Colombia Handbook of Research on Project Management Strategies and Tools for Organizational Success (pp. 281-304), IGI Global, 2020.
- SINGH, S. K., DEL GIUDICE, M., CHIERICI, R., & GRAZIANO, D. Green innovation and environmental performance: The role of green transformational leadership and green human resource management. *Technological Forecasting and Social Change*, 150, 119762, 2020.

- SONG, W., & YU, H. Green innovation strategy and green innovation: The roles of green creativity and green organizational identity. *Corporate Social Responsibility and Environmental Management*, 25(2), 135-150, 2018.
- TABASSI, A. A., Roufehaei, K. M., Ramli, M., Bakar, A. H. A., Ismail, R., & Pakir, A. H. K. Leadership competences of sustainable construction project managers. *Journal of Cleaner Production*, 124, 339-349, 2016.
- TEIXEIRA, A. A., JABBOUR, C. J. C., de SOUSA JABBOUR, A. B. L., LATAN, H., & DE OLIVEIRA, J. H. C. Green training and green supply chain management: evidence from Brazilian firms. *Journal of Cleaner Production*, 116, 170-176, 2016.
- THOMPSON, B. Exploratory and confirmatory factor analysis: Understanding concepts and applications. Washington, DC, 10694-10000, 2004.
- THOMSON, J., & JACKSON, T. Sustainable procurement in practice: lessons from local government. *Journal of Environmental Planning and Management*, 50(3), 421-444, 2007.
- ULLMAN, J. B., & BENTLER, P. M. Structural equation modeling. *Handbook of psychology*, 607-634, 2003.
- VARNÄS, A., BALFORS, B., & FAITH-ELL, C. Environmental consideration in procurement of construction contracts: current practice, problems and opportunities in green procurement in the Swedish construction industry. *Journal of Cleaner Production*, 17(13), 1214-1222, 2009.
- WALDMAN, D. A., & BASS, B. M. Transformational leadership at different phases of the innovation process. *The Journal of High Technology Management Research*, 2(2), 169-180, 1991.
- WAO, J. O. Improving Creativity in the Value Engineering Process for Green Building Construction. Paper presented at the Construction Research Congress 2018, 2018.
- WONG, J. K. W., SAN CHAN, J. K., & WADU, M. J. Facilitating effective green procurement in construction projects: An empirical study of the enablers. *Journal of Cleaner Production*, 135, 859-871, 2016.
- YI, L., UDDIN, M., DAS, A. K., MAHMOOD, M., & SOHEL, S. M. Do transformational leaders engage employees in sustainable innovative work behaviour? Perspective from a developing country. *Sustainability*, 11(9), 2485, 2019.
- YONG, J. Y., YUSLIZA, M., RAMAYAH, T., & FAWEHINMI, O. Nexus between green intellectual capital and green human resource management. *Journal of Cleaner Production*, 215, 364-374, 2019.
- YONG, Y. C., & MUSTAFFA, N. E. Analysis of factors critical to construction project success in Malaysia. *Engineering, Construction and Architectural Management*, 2012.
- ZEPPEL, H. Green procurement by local government: a review of sustainability criteria: University of Southern Queensland, 2014.
- ZHOU, S., ZHANG, D., LYU, C., & ZHANG, H. Does seeing “mind acts upon mind” affect green psychological climate and green product development performance? The role of matching between green transformational leadership and individual green values. *Sustainability*, 10(9), 3206, 2018.