



THE SUSTAINABLE POTENTIAL OF HYDROKINETIC TURBINES IN THE AMAZON BASIN

O potencial sustentável das turbinas hidrocínéticas na Bacia Amazônica

Isomar Lima da Silva, Frank Choite Ikuno, Marcus Vinicius Martins Melo, Vladimir Quéops Gameleira Nunes
Instituto Conectus - Tecnologia e Biotecnologia do Amazonas
Email: isomar.lima@msn.com, nk2030@gmail.com, marcus.melo@conectus.org.br, vladimir.queops@conectus.org.br

ABSTRACT

The Amazon, rich in biodiversity and natural resources, seeks renewable energy sources to minimize environmental impacts and reduce dependence on non-renewable sources. Hydrokinetic turbines emerge as a promising alternative by making it possible to convert the kinetic energy of river currents into electricity, without the need for dams. This study focuses on exploring the sustainable potential of hydrokinetic turbines in the Amazon region. For this, a prototype hydroelectric power plant that uses a hydrokinetic turbine was developed, and the feasibility of this technology as a renewable energy source was examined. The research included 3D modeling and propeller printing for the prototype, using materials such as carbon steel and 3D printing. The electrical components were dimensioned according to current technical standards, including cables, circuit breakers, batteries and converters. The methodology included tests on the real environment of a river in the Amazon region, evaluating the power generation capacity and the adaptability of the system to local conditions. The results demonstrated that the prototype is capable of producing electrical energy efficiently, taking advantage of the strength of river currents. The flexibility of the blades allowed adjustments according to the geometry of the watercourse, increasing the versatility of the system. In addition, the modular approach of turbines has shown promise for scalability and installation in different scenarios. This study contributes to the understanding of the potential of hydrokinetic turbines in the Amazon region, offering a renewable solution for electricity generation. The combination of technologies such as 3D printing, structural and electrical modeling has resulted in a prototype adaptable to local conditions, with the potential to provide clean energy to riverine communities, reducing dependence on non-renewable sources and promoting the sustainable development of the region.

Keywords: Axial turbine, Hydrokinetic energy, Renewable energy.

ACEITO EM: 25/09/2024

PUBLICADO EM: 30/10/2024



O POTENCIAL SUSTENTÁVEL DAS TURBINAS HIDROKINÉTICAS NA BACIA AMAZÔNICA

The sustainable potential of hydrokinetic turbines in the Amazon Basin

Isomar Lima da Silva, Frank Choite Ikuno, Marcus Vinicius Martins Melo, Vladimir Quéops Gameleira Nunes
Instituto Conectus - Tecnologia e Biotecnologia do Amazonas
Email: isomar.lima@msn.com, nk2030@gmail.com, marcus.melo@conectus.org.br, vladimir.queops@conectus.org.br

RESUMO

A Amazônia, rica em biodiversidade e recursos naturais, busca fontes renováveis de energia para minimizar os impactos ambientais e reduzir a dependência de fontes não renováveis. As turbinas hidrocinéticas surgem como uma alternativa promissora ao possibilitar a conversão da energia cinética das correntes fluviais em eletricidade, sem a necessidade de barragens. Este estudo tem como foco explorar o potencial sustentável das turbinas hidrocinéticas na região amazônica. Para isso, foi desenvolvido um protótipo de usina hidrelétrica que utiliza uma turbina hidrocinética, e foi examinada a viabilidade dessa tecnologia como fonte de energia renovável. A pesquisa incluiu modelagem 3D e impressão de hélice para o protótipo, usando materiais como aço carbono e impressão 3D. Os componentes elétricos foram dimensionados de acordo com as normas técnicas vigentes, incluindo cabos, disjuntores, baterias e conversores. A metodologia incluiu testes sobre o ambiente real de um rio na região amazônica, avaliando a capacidade de geração de energia e a adaptabilidade do sistema às condições locais. Os resultados demonstraram que o protótipo é capaz de produzir energia elétrica de forma eficiente, aproveitando a força das correntes fluviais. A flexibilidade das pás permitiu ajustes de acordo com a geometria do curso d'água, aumentando a versatilidade do sistema. Além disso, a abordagem modular das turbinas tem se mostrado promissora para escalabilidade e instalação em diferentes cenários. Este estudo contribui para o entendimento do potencial das turbinas hidrocinéticas na região amazônica, oferecendo uma solução renovável para geração de energia elétrica. A combinação de tecnologias como impressão 3D, modelagem estrutural e elétrica resultou em um protótipo adaptável às condições locais, com potencial para fornecer energia limpa às comunidades ribeirinhas, reduzindo a dependência de fontes não renováveis e promovendo o desenvolvimento sustentável da região.

Palavras-chave: Turbina axial, Energia hidrocinética, Energia renovável.

INTRODUCTION

The Brazilian Amazon region is a place rich in natural resources, including renewable energy sources such as solar energy, hydroelectricity, hydrokinetic, and biomass. The utilization of these energy sources has been regarded as a significant alternative to decreasing the region's dependence on non-renewable energy sources and reduce its carbon footprint.

The extensive hydrographic network is a crucial energy source in the Amazon region, with numerous rivers and reservoirs that can be harnessed for electricity generation. Additionally, the region boasts abundant biomass resources, including forests and agricultural crops, which can be converted into fuels for energy generation.

Hydrokinetic energy, generated through a hydrokinetic turbine, is also gaining prominence in the region, with increased research and development efforts from major R&D institutes in the northern area aiming for a symbiosis between industrialization and sustainable human development.

Hydrokinetic turbines are devices employed to convert the kinetic energy of river or canal currents into electrical energy. Their operation occurs without the need for a dam, making their implementation simpler and more accessible compared to conventional hydroelectric power plants. Moreover, hydrokinetic turbines have lesser environmental impacts and efficiently harness renewable energy sources (Sood & Singal, 2022; Fouz, 2022).

In this context, the use of renewable energy in the Amazon region carries numerous benefits, including reducing reliance on non-renewable energy sources and enhancing energy security. Furthermore, utilizing renewable energy sources can contribute to environmental preservation and mitigate emissions harmful to the ecosystem. It can also serve as a significant income source for local communities, particularly small communities that can generate energy for their own needs.

However, despite the benefits, the adoption of renewable energy in the Amazon region still faces challenges. For instance, a lack of infrastructure and access to suitable technology can hinder the development of renewable energy projects. Additionally, poorly executed projects can have adverse effects on biodiversity and local communities. Addressing these challenges carefully is crucial to fully leveraging the benefits of renewable energy in the Amazon region.

This study presents the design and testing of a minielectric power plant using a hydrokinetic turbine to generate 2.5 ampere-hours in a river within the Amazon basin.

To aid comprehension, this work is divided into four sections. Section 2 introduces the key concepts underpinning this study; Section 3 outlines the primary materials and methods employed; and Section 4 presents the main results and relevant conclusions.

1 BACKGROUND

1.1 Axial turbine description

The literature shows us that the first turbine for river currents was developed and tested in a real environment by Peter Garman around 1978. The developed mechanism was called the Garman turbine and was part of the Intermediate Technology Development Group (ITDG) initiative. It was constructed and tested in Juba, Sudan, in the White Nile (Garman, 1986). The project consisted of a fully submerged vertical-axis turbine moored to a post on the bank. Later on, the project was modified to a horizontally inclined axis turbine with a flotation system and a somewhat similar anchoring approach (Figure 3). The data derived from this project indicated low development and implementation costs and satisfactory energy generation efficiency.

The study by Garman, (1986) allowed for the development and testing of various configurations and arrangements of hydrokinetic turbines available for the current study. The primary distinction for hydrokinetic turbines is related to the orientation of their axis in relation to the direction of water flow through the equipment. These characteristics allow for the classification of these turbines into axial flow turbines and cross-flow turbines.

Furthermore, there are subcategories within the groups of axial flow and cross-flow turbines. Figure 1 presents the main subcategories within these two groups (Eriksson, 2008; Garman, 1986).

Figure 1 - Classification of hydrokinetic turbines

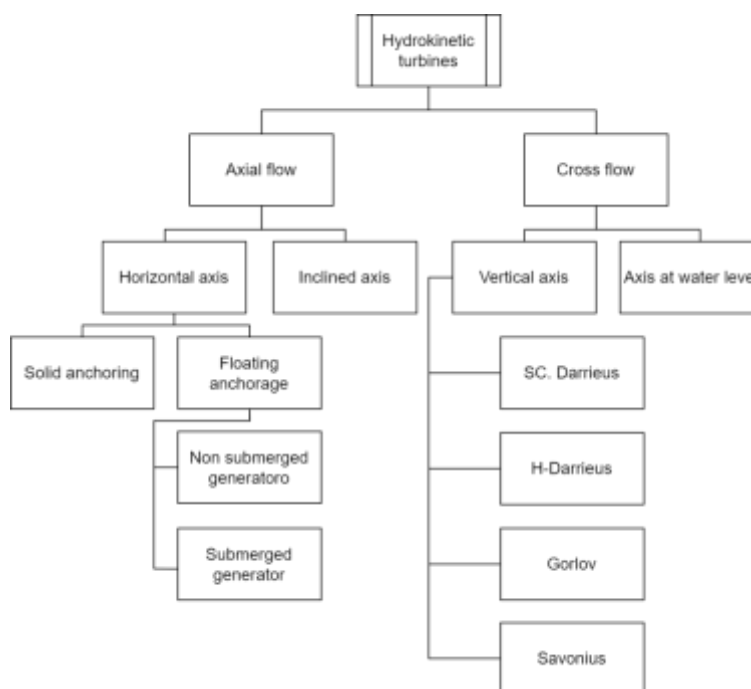

Source: Author (2023)

As turbinas de fluxo axial são classificadas como turbinas de fluxo axial com eixo horizontal e as de eixo inclinado. Para a geração de energia nos rios e mares as mais utilizadas são as de eixo horizontal (Figura 3), no que se refere a pequenos rios e córregos são mais utilizadas às turbinas de fluxo axial de eixo inclinado, conforme Figura 2, (Khan, 2020).

A captura e transferência da energia cinética da corrente de água pela turbina axial pode ser em apenas uma fração da energia cinética da água, ocorrendo pela seção transversal do equipamento, essa fração é conhecida como coeficiente de potência, C_p . Qual pode ser expressa como:

$$P_{capture} = C_p P_{theory} = \frac{1}{2} \rho C_p A v^3 [W] \quad (1)$$

According to Pham, (2014), the power coefficient C_p depends on the Tip-Speed Ratio (TSR), where λ is the ratio between the blade tip speed and the velocity of the flowing water (Pham, 2014). The formula for TSR is:

$$\lambda = \frac{\text{SpeedAtTheTipOfaBlade}}{\text{WaterFlowingSpeed}} = \frac{wR}{v} \quad (2)$$

The relationship between TSR and C_p is intuitively understood, where slower turbine blade rotation results in a significant portion of the water passing through the rotor without being captured by the blades. Conversely, if the turbine spins too rapidly, the blades are constantly moving through turbulent water. Thus, there is a need for sufficient time intervals between two blades to allow fresh water to enter and the next blade to harness the energy of this fresh water, avoiding the use of turbulent water (Pham, 2014), (Riegler, 1983).

Figure 2 - Horizontal axis turbine with a 90° submerged drive mechanism (Floating mooring)

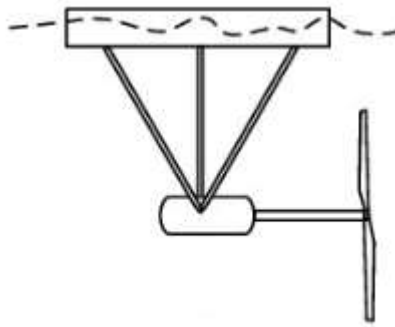

Source: Khan (2020)

Figure 3 - Inclined shaft axial flow turbines

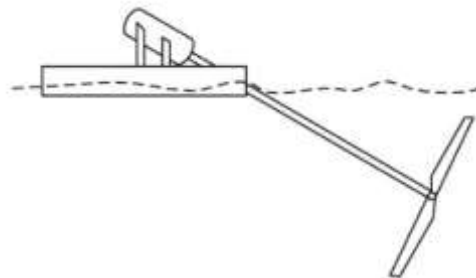

Source: Khan (2020)

Figure 4 - Horizontal Axis Axial Flow Turbines (Rigid Mooring)

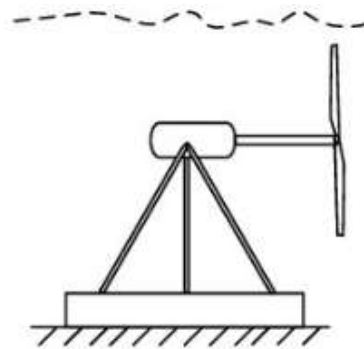

Source: Khan (2020)

Conventional axial turbines are devices that operate under low-head conditions, meaning drop heights between 70 and up to 5 meters (Botan et al., 2016).

The SHF4 axial turbine can be installed by floating on pontoons or mounted beneath a bridge in channels.

It generates up to 0.6 kW, with a current velocity of 2.5 m/s.

Several can be placed in parallel, spaced apart by 15 meters.

Output is 48VDC and 220V-50Hz or 110V-60Hz.

You can store up to 14 kWh per day in batteries.

Hydrokinetic turbines, with a 1830 mm axial rotor submerged 2.0 meters, generate up to 4 kW at 2.8 m/s, offering both single-phase and three-phase output.

1.1.1 Cross-Flow Turbines

Cross-flow turbines are hydraulic turbines that operate based on the principle of cross-flow water movement through their blades. The turbine's shaft and rotor are perpendicular to the direction of water flow; as a result, the blades are powered by the cross-flow of water instead of flowing along the turbine's axis. This leads to high energy conversion efficiency, making cross-flow turbines a popular choice for small hydropower plants. Furthermore, this type of turbine is simpler in terms of construction and maintenance compared to other types of hydraulic turbines, and it emits less noise due to reduced losses at the blade tips. However, its efficiency can be affected by variations in water volume and pressure, necessitating additional care in installation and operation (Vermaak, 2014). Figures 05 and 06 depict examples of cross-flow turbines.

Figure 5 - Cross flow turbines (Savonius)



Source: Vermaak (2014)

Figure 6 - Cross flow turbines (H-Darrieus Rotor)



Source: Vermaak (2014)

1.2 Renewable Energy Sources

The literature presents renewable energy as a source of energy that can be naturally replenished over time (Pham, 2014). This energy source serves as an alternative to fossil fuels, which have limited resources and a negative environmental impact. Examples of renewable energy sources include:

- **Wind Energy:** Wind energy generation harnesses the power of the wind. This process is carried out through wind turbines that convert wind energy into electricity. This type of renewable energy has been widely utilized in Europe and coastal regions of the Americas and is gaining significant popularity in wind-rich countries (Gareiyou, 2021), (Kondili, 2012).
- **Solar Energy:** Solar energy, obtained from sunlight, is the most extensively used renewable energy source globally. It is converted into electricity through solar panels. This clean and renewable energy source does not emit greenhouse gases on a significant scale, thus having minimal macro environmental impact (Gareiyou, 2021).
- **Hydropower:** This energy is generated by utilizing water flow. Dams are constructed to store water, which is then released to generate electricity. Hydropower is a reliable and renewable energy source, but it can also have a negative environmental impact, such as altering river flow and disrupting wildlife habitats.
- **Bioenergy:** Bioenergy is generated from renewable biological sources, such as biomass, biogas, and bioethanol. Biomass is obtained from agricultural residues, while biogas is generated from organic waste. Bioethanol is produced through the fermentation of sugars found in plants like sugarcane, corn, and beets. Bioenergy is a renewable and sustainable energy source, but it can also have negative impacts, such as competing with food crops for land and emitting gases.
- **Geothermal Energy:** Geothermal energy involves harnessing heat from within the Earth's interior in geologically active areas. It is used to produce steam which, in turn, is utilized to generate electricity (Gude, 2018).

Hydrokinetic Energy: Hydrokinetic energy is the energy present in the currents of rivers and oceans. This energy can be transformed into electrical energy through mini power plants, which utilize the force of moving water to spin hydrokinetic turbines and generate electricity. It is considered renewable, as water is constantly replenished through natural processes such as rainfall and glacier melting (Sood & Singal, 2022), (Fouz, 2022).

2 MATERIALS AND METHODS

In this section, we describe the materials used and the methodology employed in the development and testing of the hydrokinetic generator prototype. We detail the equipment, tools, and procedures that were adopted to achieve the objectives outlined in the scope of the study.

2.1 Materials Used

The list of materials used for the elaboration of the hydrokinetic generator prototype is presented as follows:

2.1.1 Structural Materials

Carbon Steel "U" Beams 40x80x2.3mm for the Frame Structure: Carbon steel "U" beams were used in the construction of the frame structure, which supports and directs the generator components. Carbon steel was chosen due to its high mechanical strength and durability, ensuring that the structure is robust and capable of withstanding the adverse environmental conditions of the aquatic environment where the generator will be installed.

Black PC-ABS Base Material for 3D Printing of Blades: The black PC-ABS base material is used for 3D printing of the generator's blades. PC-ABS is a combination of polycarbonate (PC) and acrylonitrile butadiene

styrene (ABS), which combines the strength and rigidity of polycarbonate with the durability and ease of processing of ABS. The choice of black color is advantageous as it helps absorb ultraviolet light in the aquatic environment, avoiding unwanted reflections during operation.

SR-110 Material as Support Material for 3D Printing of Blades: The SR-110 material is used as a support material for 3D printing of the blades. This material is soluble in a specific chemical agent, which allows for easy removal of the supports after printing. With the supports removed, the printed blades are ready for use, ensuring precise and smooth geometry for efficient generator operation.

2.1.2 Electrical Components

The list of electrical materials required for the hydrokinetic generator project includes:

- Two-core cables for conducting electrical energy;
- Three-pole circuit breaker for electrical system protection;
- Power resistors for electrical testing and simulations;
- Electrical battery for energy storage;
- Dynamo for converting blade torque into electricity.

The hydrokinetic generator aimed to produce a three-phase voltage of 33VAC due to the rotational motion of the blades. This voltage is transmitted via cables to an alternating current (AC) to direct current (DC) voltage converter. This same direct current voltage is applied to the inverter, whose output is a 12VDC voltage and an amplified residential-use two-phase (AC) voltage of 110VAC. The converter and inverter models are shown in Figures 7 and 8.

Figure 7 - 33VAC/12VDC Converter



Source: Author (2023)

Figure 8 - 12VDC/110VAC inverter



Source: Author (2023)

After the completion of the 3D modeling phase, the electrical project development began, based on technical specifications and regulatory standards NR10 and NBR5410. The sizing of the main electrical protection devices was carried out considering the load to be driven, with obtaining information about power and angular velocity. The maximum current produced by the hydrokinetic generator was analyzed, and based on this value, the cables, circuit breakers, resistive loads, and necessary electrical batteries were specified for the proper operation of the system.

2.2 Prototype Development

The development of the hydrokinetic generator prototype (Figures 9 and 10) was divided into distinct stages:

Figure 9 - Axial Turbine



Source: Author (2023)

Figure 10 - Axial turbine profile

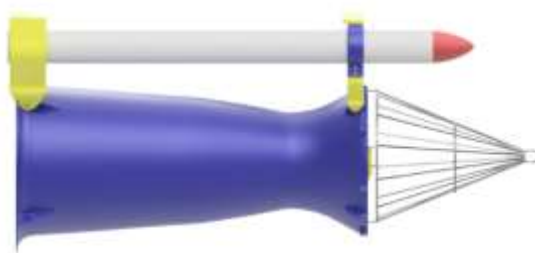

Source: Author (2023)

2.2.1 3D Modeling

In this stage, actions were taken to model mechanical drawings and develop electrical diagrams using Inventor software. 3D drawings of the envisioned components were created, considering the available dimensions for installation and process specifications. The structural part of the prototype was designed, and the selected material for the framework was the "U" shaped carbon steel beam 40x80x2.3mm. Detailed 2D drawings were prepared for fabrication and to identify potential peculiarities during on-site installation. See Figures 11 and 12.

Figure 11 - System assembled at the test site

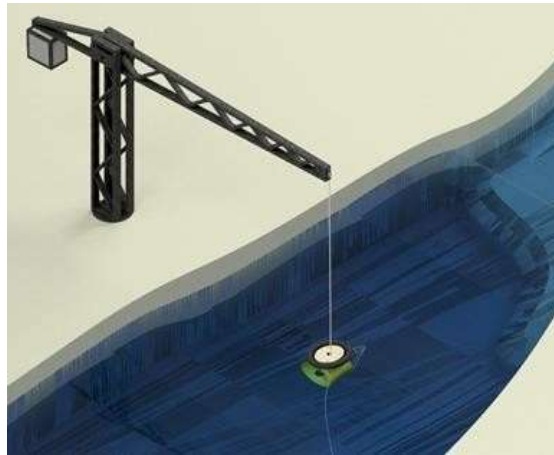

Source: Author (2023)

Figure 12 - Hydrokinetic generator concept



Source: Author (2023)

After creating the main 3D drawings with the assistance of Inventor software, 2D drawings of key components requiring fabrication or modification were generated. This stage aims to adhere to the technical criteria and dimensions established by the engineering team during the project development phase.

2.2.2 Prototype of Blades

Three versions of blades were developed, each with different geometries and numbers of blades (V01 in Figure 13, V02 in Figure 14, and V03 in Figure 15, with the goal of assessing the generator's efficiency in terms of energy generation. 3D printing was employed to create the blades, using black PC-ABS as the base material, and SR-110 support material during the printing process.

Figure 13 - Printed propeller V01



Source: Author (2023)

Figure 14 - Printed propeller V02



Source: Author (2023)

Figure 15 - Printed propeller V03



Source: Author (2023)

The printing process for the blades utilized the PC-ABS base material in Black color, and the SR-110 material was used for support as specified by the printer manufacturer. The choice of this material was based on the material limitations of the Fortus 450mc printer model and the availability of the necessary quantity of material at the time of printing.

A four-blade and two-level blade was developed to enhance the generator's efficiency in energy generation. Due to the complex geometry of the component, 3D printing was selected as the manufacturing method, with adjustments made to the thickness to ensure the mechanical strength of the blade.

A modular version (Figure 16) was also developed, allowing for replication of the construction without relying on plastic injection, thereby facilitating small-scale production and prototype assembly. Each module comprises a conical stainless-steel duct and a transmission shaft that connects to the blade, enabling multiple modules to be connected to a single generator.

Figure 16 - Module 1 design

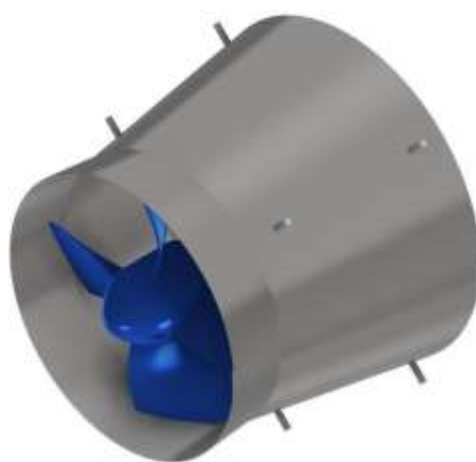

Source: Author (2023)

The modular system (Figure 17) allows for the sizing of the torque generated by the blade assembly to drive the generator, enabling the application of a reduction or amplification of rotation ratio according to the specific needs of each region where the generator will be installed. The peculiarities of each watercourse are considered, including factors such as current velocity, depth and width of the watercourse, as well as the consumption demand of the riverside communities. In this way, the project is adapted appropriately for each scenario, ensuring maximum efficiency and utilization of the available water resource.

Figure 17 - Module design with 2 ducts



Source: Author (2023)

The modular assembly can be easily put together using four ducts, with the consideration that the weight and dimensions of the system will increase as more sets are added. The assembly can be done in series or in parallel, allowing it to accommodate both watercourses that have a greater width compared to depth, and those with the inverse relationship. This flexibility in the system arrangement ensures that the project can be adapted according to the specific characteristics of each watercourse, providing an efficient and versatile solution for different hydrographic scenarios. Figures 18 and 19 depict the assembly of the sets in series or in parallel.

Figure 18 - Module design with 3 ducts in series



Source: Author (2023)

Figure 19 - Module design with 4 ducts in parallel



Source: Author (2023)

2.3 Turbine Prototype

During the turbine prototyping phase (Figure 20), a series of components were both fabricated and modified, culminating in the assembly of the enhanced generator model. This effort was driven by the goal of aligning with the demand and specifications outlined within the study's scope (Figure 21). To provide a comprehensive comparative analysis, a set of preliminary tests was conducted on the generator, aiming to assess its operational status at that juncture and gauge the level of efficiency the system would achieve following all necessary modifications. This stage played a pivotal role in evaluating the performance and viability of the proposed

enhancements, ultimately ensuring the project's attainment of the intended outcomes and meeting the distinct needs of the riverside communities.

Figure 20 - Assembly and preliminary tests



Source: Author (2023)

Figure 20 - System setup

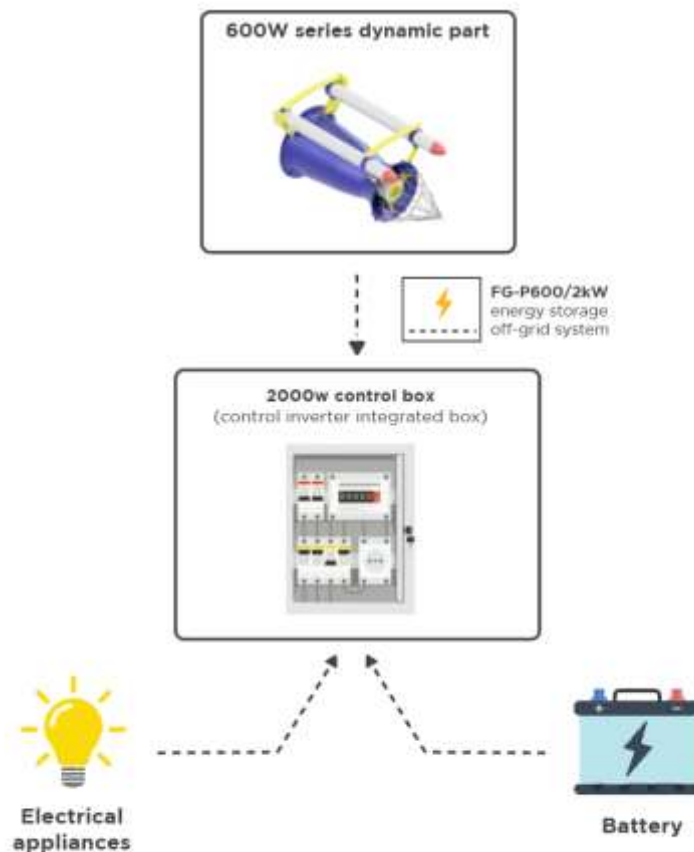

Source: Author (2023)

Due to the nature of the manufacturing process based on extrusion lines, there was a loss of mechanical strength compared to plastic injection and machining processes. This decrease in strength was related to the fragility of the line thickness and the contact surface used to join them all. Therefore, when the part was intended to support loads and stresses, it became necessary to reinforce its structure to ensure the mechanical strength required for its

proper functioning. This measure was essential to guarantee the durability and efficiency of the component in its practical applications.

3 APPLICATION AND VALIDATION

The application of the hydrokinetic turbine in the Procópio Stream considered the factors described in the subsections of section 4.2 of this study. The method used aimed to harness the energy of the flowing water to generate electricity. The utilized turbine operates by capturing the kinetic energy of the flowing water, converting it into mechanical energy, which is then used to rotate an electric generator.

3.1 Environmental Impact

The real-world application of the equipment considered the assessment of the turbine installation's impact on the river's ecosystem, including aquatic fauna and water quality. The analysis conducted by the project engineers concluded that the use of hydrokinetic turbines may have minimal environmental impacts due to their small scale compared to hydroelectric projects. Regarding the alteration of the hydrological regime: hydrokinetic turbines might minimally alter the speed and direction of the water current, which could have an infinitesimal effect on water quality and ecological balance. In small streams, the turbine movement could disrupt fish migration, which might affect their reproduction and fish population in the area. Therefore, it is recommended to install them in watercourses where fish reproduction does not occur. Habitat alteration is low since most hydrokinetic turbines are installed on floating buoys, eliminating the need for dam and canal construction for installation. Another factor considered in the environmental impact analysis was noise emissions; the equipment used in this study has low noise emissions during operation, which is not detrimental to aquatic animals and local fauna (Rashki, 2022). It is emphasized that the turbine used in this study has positive impacts, such as generating clean and renewable energy and reducing emissions of pollutants. It is important to consider all impacts when assessing the feasibility of a hydrokinetic power plant and ensure that mitigation measures are implemented.

3.2 Financial Viability

An evaluation was conducted to determine the financial feasibility of the project, i.e., whether it could be carried out based on the available financial circumstances. This assessment considered aspects such as installation costs, maintenance, operation, among others, as well as potential revenues and sources of financing, in order to estimate whether the project would be financially viable over time for the more isolated communities in the region. The project team estimated the cost of turbine installation and maintenance, comparing it with other energy sources. The technical and economic feasibility of small hydroelectric power plants (SHP) was also estimated based on studies (Weiller, 2014), (Moaraes, 2010), (Veja, 2008) available in the literature. Weiller considered a 525 kW SHP with a cost of R\$ 4,067/kW, Moraes considered a 24 MW SHP with a cost of R\$ 4,487/MW, and Canales presented an average cost of US\$3,254.10/kW for SHP implementation. The study by Cruz (2005) compares a hydrokinetic power generation system with a considered power of 4 kW and a hydrokinetic energy generation cost of R\$ 0.45 kWh. In this analysis, the author did not consider the operation and maintenance cost of the hydrokinetic installation. Authors take into account both objective and subjective factors in their studies, which can vary, such as size, location, construction complexity, and regulatory costs. Additionally, the cost per unit of installed power can be influenced by economic and political factors, such as electricity supply and demand, interest rates, inflation, among others. A simplified estimation for the feasibility analysis of small hydroelectric power plants (SHP) involves summing the value of all components and then dividing it by the total installed power of the plant. This is a purely financial approach that provides a parameter for comparing the financial return on investment. Based on the team's evaluation considering the variables and indicators presented in this study, it was concluded that the SHF hydrokinetic turbine meets the main requirements for project implementation.

3.3 Sustainability

The analysis of the long-term viability of turbine utilization considered factors such as variations in river water levels throughout the year and the need for regular maintenance. Other important factors include water resources, social responsibility, durability, and governmental regulations. This study took these factors into account to analyze the sustainability of hydrokinetic turbine utilization. This assessment helped determine the project's long-term viability, considering that the project addresses environmental, social, economic, and technological issues. The data show that:

- The water resources of the Amazon basin are available over time, even considering seasonal variations and climate trends. The rivers have high flow rates, making the region potentially suitable for the installation of renewable energy projects, such as hydrokinetic.
- Environmental impact: The verification indicates that the installation of hydrokinetic turbines has minimal negative consequences on the river ecosystem, aquatic fauna, and water quality.
- Social responsibility: It provides data that allow us to estimate that the turbine's lifespan is long and maintenance costs over time are low.
- Governmental regulations: The Brazilian government establishes regulations for the use of hydrokinetic turbines through the norms of the Brazilian Institute of Environment and Renewable Natural Resources (IBAMA) and the National Water Agency (ANA). These regulations cover issues such as environmental licensing, water resource management, and impacts on aquatic fauna. Additionally, it is necessary to follow the technical standards of the Brazilian Association of Technical Standards (ABNT) for turbine construction and installation.

Other regulations, such as requirements for the construction and operation of hydroelectric power plants, including hydrokinetic, considering aspects like safety, environment, energy efficiency, and quality of the supplied energy, are established by the Ministry of Mines and Energy and the National Electric Energy Agency (ANEEL).

3.4 Laboratory Testing

In order to validate the prototype's functionality and identify potential design flaws, laboratory tests were conducted. The relationship between generator rotation and three-phase voltage at the output terminals was measured using a test bench that simulated the aquatic environment. To measure the speed-to-voltage relationship of the generator, a test bench (Figure 21) was set up to simulate the installation in an aquatic environment. This approach allowed for indirectly obtaining the generator's rotation by analyzing the three-phase voltage at its output terminals. In assembling the test bench, a 0.5 hp AC three-phase motor, the dynamo designated for the generator, a phenolic sheet, a polyacetal support, four aluminum bases, and an aluminum coupling to interconnect the motor and dynamo shafts were utilized. This experimental configuration provided the necessary data for evaluating the speed-to-voltage relationship of the generator, contributing to the understanding of the device's performance under conditions closely resembling real operating conditions in an aquatic environment.

Figure 21 - Test bench



Source: Author (2023)

The motor was controlled through an electrical panel (Figure 22), which incorporated a frequency inverter, allowing precise and adjustable knowledge of the motor's operating speed. This control system configuration provided the capability to vary the motor speed in a controlled manner, enabling the attainment of different operating conditions during the tests conducted on the test bench. In this way, it was possible to analyze the generator's performance concerning speed variations, providing valuable data for the characterization and optimization of the equipment.

Figure 22 - Electric panel AC motor speed regulator



Source: Author (2023)

During the test (Figure 23), 13 samples corresponding to different motor output speeds were collected. At each speed point, the three-phase voltage produced by the generator was carefully measured and recorded. This approach allowed the construction of a graph that detailed the generator's behavior in relation to the operating speed. Based on this analysis, it was possible to establish a reversible relationship between the shaft rotation and

the generator's output voltage, providing a more comprehensive and valuable characterization of the system's properties under different operational conditions.

Figure 23 - Voltage acquisition as a function of generator rotation



Source: Author (2023)

To perform bench tests, a tachometer (Figure 24) was developed using an optical barrier sensor. This system was designed to count the number of blades on the propeller that passed through the sensor. Each time the sensor's light was interrupted by a blade, a programmable logic controller (PLC) recorded this occurrence. After three complete passes of the propeller, the PLC recognized that the propeller had completed one full rotation. Over the course of a minute, the PLC recorded the total number of propeller rotations, allowing for the accurate and efficient calculation of the propeller's rotations per minute (rpm). This homemade tachometer provided a reliable tool for measuring the system's rotations in tests, facilitating the analysis and evaluation of the performance characteristics of the hydrokinetic turbine.

Figure 24 - Using the Tachometer



Source: Author (2023)

3.5 Field Tests

Following the laboratory tests, the prototype was taken to the field for analysis of its performance under real conditions. The tests were conducted at the Procópio Creek, situated in the municipality of Rio Preto da Eva, Amazonas (Figure 25). The water velocity and other environmental factors were taken into account to assess the generator's performance in an aquatic environment.

Figure 25 - Localização do campo de teste



Source: Author (2023)

3.6 Analysis of Laboratory and Field Test Results

The data collected during both laboratory and field tests were analyzed to determine the efficiency of the prototype and identify the propeller geometry that achieved the best performance in terms of energy generation. The relationship between propeller rotation speed and generator output voltage was used to assess the system's real-time behavior.

3.7 Ethical Considerations

Throughout the project development, regulatory standards and ethical norms related to electrical safety, environmental protection, and respect for the local communities involved in the field tests were adhered to.

3.8 Study Limitations

The main limitations of the study include the challenge of measuring propeller rotation after installation in an aquatic environment and variations in environmental conditions that can affect the results obtained during field tests.

3.9 Analysis of Turbine Energy Efficiency

It is important to highlight that, during the course of the field tests, comparative analyses were conducted to evaluate the performance of four distinct propeller geometries. This comparative analysis aimed to determine which propeller configuration could offer the highest efficiency to the energy generation system. The variation in propeller geometries was a crucial approach to identify the one that would best adapt to the specific hydrodynamic conditions of the environment. Each propeller configuration had unique characteristics that influenced its interaction with the water flow, resulting in different levels of efficiency in converting kinetic energy into electricity. Energy efficiency was evaluated in terms of two main parameters: alternating current (AC) generation voltage and revolutions per minute (RPM). These values were measured and recorded during the field tests for each of the four propeller geometries. The AC generation voltage directly reflected the amount of electrical energy

produced by the turbine, while RPM indicated the rotation speed of the turbine under the water flow. The results were consolidated in Table 1, highlighting the corresponding AC generation voltages and RPMs for each propeller configuration. This table provided a clear view of performance differences among the tested propellers. Additionally, these data were graphically visualized to allow for a more intuitive analysis of behavior trends. From these results, the efficiency percentage was calculated for each propeller geometry compared to the reference model. This calculation provided a quantitative perspective on the relative performance of each configuration. Furthermore, the relationships between voltage and RPM were used to plot power curves versus speed for each propeller geometry, enabling a detailed understanding of the system's behavior under different operating conditions. After a thorough analysis of the field test results, it became possible to identify the most efficient propeller configuration in terms of energy generation. It became evident that the eight-blade propeller exhibited the best voltage-to-RPM ratio, highlighting it as the highest-yielding option among the evaluated geometries. In summary, the analysis of turbine energy efficiency was an essential component in determining which propeller configuration could optimize the conversion of kinetic energy into electricity. This process allowed for the selection of the most suitable geometry to maximize the energy generation potential of the hydrokinetic turbine.

3.9.1 Measurement and Results

The comparative assessment of the performance of the different developed propeller geometries necessitated immersing the propellers under controlled conditions for a fixed period. This procedure aimed at collecting precise data on voltage and revolutions per minute (RPM), providing a comprehensive understanding of the behavior of each propeller configuration under the water flow.

The obtained results were organized in Table 1, illustrating the measurements of alternating current (AC) generation voltage and corresponding RPM for the four propeller geometries: three blades, four blades, helical, and eight blades.

Table 1 - Percentage of calculated efficiency. Source: Author (2023)

Propeller	Percentage
4 blade propeller	98,92%
Helical Helix	54,59%
8 blade propeller	108,65%

Furthermore, the results were graphically visualized, enabling a more accessible visual interpretation of the relationships between voltage and RPM. The comparative graph depicted in Figure 26 highlighted the subtleties of the performance curves of the propellers, revealing trends and notable differences among the tested geometries.

Figure 26 - Comparativo entre a rotação e a tensão das hélices

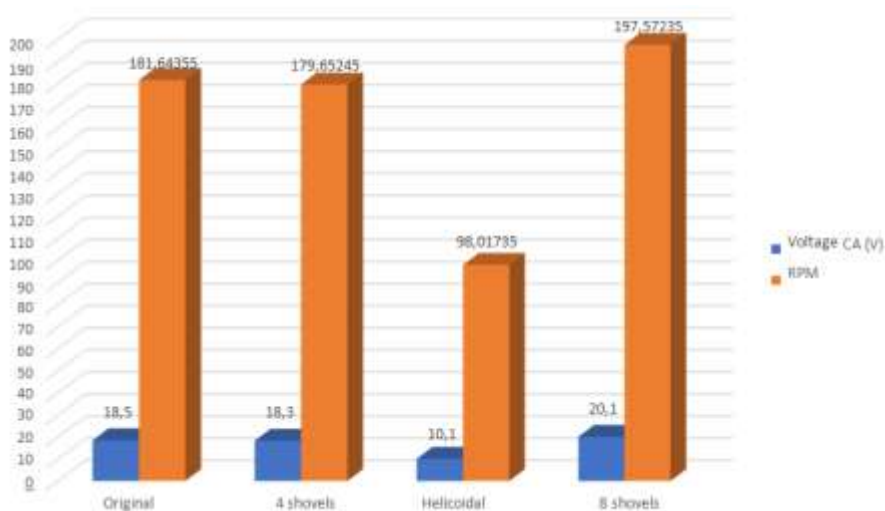

Source: Author (2023)

Based on the calculated theoretical efficiency, a comprehensive comparative study was conducted among all propeller geometries. This study aimed to plot the power curve against velocity (Figure 27), using both the original equipment data and the calculations for the developed propellers. This analysis allowed for the assessment of efficiency variations across operational velocity ranges, providing crucial insights into the energy generation capability of the different geometries.

Figure 27 - Comparativo entre Potência e Velocidade

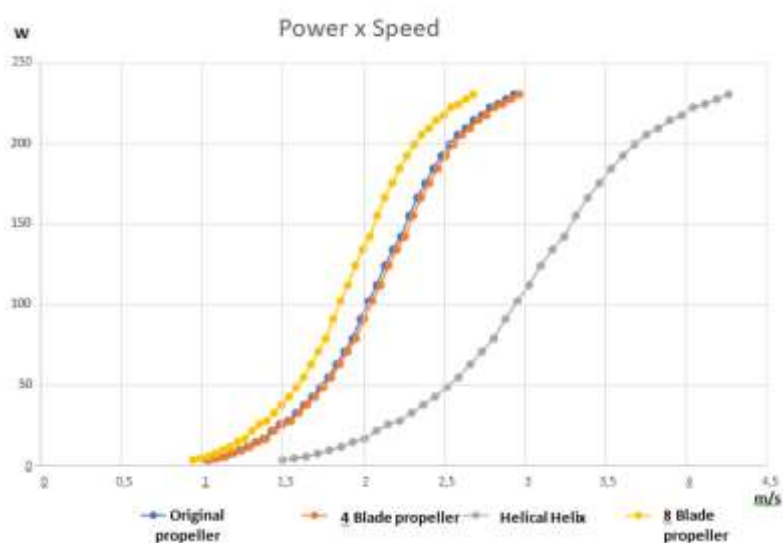

Source: Author (2023)

The analysis of results from the field tests clearly indicated that the eight-blade propeller stood out, displaying the best relationship between voltage and RPM. This outcome underscores the capability of this geometry to achieve the highest energy efficiency among all tested configurations.

In summary, the Measurement and Results subsection was crucial in demonstrating the methodology and outcomes derived from the comparative analysis of propeller geometries. This analysis provided concrete justification for selecting the eight-blade geometry as the most efficient in terms of converting kinetic energy into electrical energy under specific testing conditions.

4 RESULTS

The evaluation of the results of this study considered both the efficiency of the hydrokinetic turbine in different propeller geometries and the potential for energy generation to power residential equipment. To establish a theoretical context, various typical components of a household and their associated powers were identified, as shown in Table 2. This survey allowed for a comprehensive analysis of the energy demands of a standard residence.

Table 2 - Theoretical equipment of the house. Source: Author (2023)

Equipment	Amount	Power (W)	Total power (W)
Light bulb	3	15	45
Refrigerator	1	250	250
Fan	1	100	100
Television	1	90	90
		TOTAL	485

During the conducted tests, it was observed that utilizing a turbine with an eight-blade geometry exhibited the capability to generate energy equivalent to 2.5Ah. Based on this realization, the possibility of pairing two turbines in parallel would enable a generation potential of up to 5Ah. Such potential renders the charging of a 50Ah/12V battery achievable within a mere ten-hour period. With this energy storage capacity and the presence of a 500W DC/AC converter, the energy autonomy of residential equipment was calculated. In a scenario where all devices were operating at maximum power, the autonomy would be approximately one hour. However, if only the refrigerator were in operation, the autonomy would extend to around two and a half hours.

It's worth noting that numerous opportunities for enhancing autonomy exist, whether through the addition of more turbines or the incorporation of additional batteries. However, a fundamental factor to ensure full battery charging is the river current where the turbine will be installed. This current must be capable of rotating the turbine's motor at a minimum speed of 120 RPM, ensuring the effectiveness of energy generation.

The obtained results unveiled the viability of utilizing hydrokinetic turbines as a promising source of renewable energy generation to meet residential demands. The analysis of generation and storage capabilities demonstrated that this approach can be an efficient solution, especially in remote regions with limited access to traditional energy sources. The combination of energy efficiency, reduced environmental impact, and expansion potential renders hydrokinetic turbines an appealing option in the landscape of clean energy generation.

4.1 Discussion

The process of analyzing the results obtained throughout this study revealed significant insights into the effectiveness and viability of hydrokinetic turbines as a promising source of renewable energy generation. The results and discussions can be categorized into several key areas, namely: energy efficiency of different blade geometries, practical feasibility of energy generation, environmental impact, and potential applications in diverse contexts.

Energy Efficiency of Blade Geometries

A pivotal aspect of this study was the comparative analysis of the four developed blade geometries: three blades, four blades, helical, and eight blades. Field tests allowed for precise data collection on generated voltage and rotations per minute (RPM) for each model, providing a solid foundation for efficiency evaluation. The results revealed that the eight-blade design achieved notably superior performance compared to the other tested geometries. The efficiency of this blade was evident in both the generated voltage and RPM, demonstrating an optimal relationship between these two parameters. This finding is critical for decision-making in selecting the most effective geometry to maximize energy generation.

The graphical representation of power in relation to speed for all blades provided a comprehensive visual understanding of the energy generation capabilities of each geometry. The curve corresponding to the eight-blade design stood out as the steepest and most consistent, indicating sustained energy generation across a wide range of speeds. This suggests that, for a variety of water flow conditions, the eight-blade design can consistently and reliably produce energy.

Practical Feasibility of Energy Generation

A crucial part of the discussion centered on the practical application of the results, considering real scenarios of energy generation. By calculating the energy generation potential of two hydrokinetic turbines in parallel, it was estimated that a 50Ah/12V battery could be charged in just ten hours. This finding is highly encouraging, as it suggests that hydrokinetic turbine-based systems can effectively store enough energy to power a variety of essential household equipment. Furthermore, the autonomy of these devices was discussed based on the turbine's capacity and device consumption rates, highlighting the flexibility and adaptability of this solution.

Environmental Impact and Potential

Applications One of the notable advantages discussed was the low environmental impact of hydrokinetic turbines compared to other energy sources, such as conventional hydroelectric power plants. The study emphasized that hydrokinetic turbines do not require the construction of large dams or significant alteration of watercourses, minimizing impacts on river ecosystems. This point is particularly relevant in regions like the Amazon, where preserving the natural environment is of utmost importance.

The discussion of potential applications encompassed its use not only in remote areas but also as a viable option for urban communities. The scalability of hydrokinetic turbines was mentioned as an advantage that could be leveraged to create hybrid energy generation systems, integrating them with other renewable sources to achieve a more stable and reliable energy supply.

Future Implications

In summary, the results and discussions of this study affirm hydrokinetic turbines as an effective and promising solution for renewable energy generation. The superior performance of the eight-blade geometry, coupled with low environmental impact, reinforces the feasibility of implementing this technology in various settings. However, like any technological approach, challenges remain, and opportunities for future improvements are identified.

To move forward, a deeper analysis in real deployment scenarios is essential, considering seasonal variations and fluctuations in water flow speed. Additionally, continuous optimization of blade geometry, as well as the exploration of more efficient and sustainable materials, can contribute to even further enhanced performance. The involvement of multidisciplinary experts, including engineers, ecologists, and economists, is crucial to address all technical, environmental, and social aspects in the successful implementation of hydrokinetic energy generation systems.

Ultimately, this study highlights hydrokinetic turbines as a potential catalyst for transforming the energy landscape, offering a sustainable and low-impact alternative to meet growing energy demands. Continued research and development in this field have the potential to drive widespread adoption of this technology, benefiting both the environment and the communities that rely on it.

CONCLUSION

The adoption of hydrokinetic turbines emerges as a significant milestone in the pursuit of sustainable energy generation solutions. As evidenced in this study, this unique technology harnesses the kinetic force of water currents to effectively convert this natural energy into electricity, eliminating dependence on fossil fuels and non-renewable

sources. The uniqueness of this approach lies in its ability to tap into an endless source of energy without resorting to drastic alterations in aquatic ecosystems or the surrounding landscape.

Notably, the positive and enduring impact of hydrokinetic turbines in the socio-environmental sphere stands out. Compared to conventional hydroelectric power plants, these turbines minimize direct interference with watercourses, mitigating environmental damage and avoiding massive community displacements. Such an approach resonates, especially in sensitive and valuable regions like the Amazon, where the preservation of river ecosystems is of paramount importance.

The scalability of hydrokinetic turbines presents itself as a strategic differentiator. Their ability to operate as microgeneration sources and seamlessly integrate with other renewable sources creates a resilient and diversified energy ecosystem. This flexibility positions hydrokinetic turbines as a real alternative for remote communities grappling with logistical and infrastructure challenges. Through this technology, these communities can achieve energy independence in an environmentally responsible manner.

Ultimately, the journey of hydrokinetic turbines is a testament to the power of forward-oriented innovation. They not only promote the transformation of energy paradigms but also redefine the balance between human development and environmental conservation. As this technology continues to evolve, multidisciplinary collaboration and a commitment to in-depth research become essential to solidify its potential and ensuring a cleaner, more sustainable, and energetically independent future for all.

REFERENCES

- Cruz, R. W. A. (2005). Micro-Geração de Eletricidade em Pequenas Comunidades Isoladas da Amazônia com Grupos-Geradores Hidrocinéticos e Grupo Dieselétrico. *Pch Notícias Shp News*, 16, 1-13.
- Eriksson, S., Bernhoff, H., & Leijon, M. (2008). Evaluation of different turbine concepts for wind power. *Renewable and Sustainable Energy Reviews*, 12(5), 1419-1434. DOI: <https://doi.org/10.1016/j.rser.2006.05.017>
- Fouz, D. M., Carballo, R., López, I., & Iglesias, G. (2022). A holistic methodology for hydrokinetic energy site selection. *Applied Energy*, 317, 119155. DOI: <https://doi.org/10.1016/j.apenergy.2022.119155>
- Gareiou, Z., Drimili, E., & Zervas, E. (2021). Public acceptance of renewable energy sources. In G. L. Kyriakopoulos (Ed.), *Low Carbon Energy Technologies in Sustainable Energy Systems*, 309-327. Academic Press. DOI: <https://doi.org/10.1016/B978-0-12-822897-5.00012-2>
- Garman, P. (1986). *A Fieldworker's Guide*. Intermediate Technology Publishing. London, UK.
- Gude, V. G. (2018). Chapter 4 - Geothermal Source for Water Desalination—Challenges and Opportunities. In V. G. Gude (Ed.), *Renewable Energy Powered Desalination Handbook*, 141-176. Butterworth-Heinemann. DOI: <https://doi.org/10.1016/B978-0-12-815244-7.00004-0>
- Khan, J., Iqbal, M. T., & Quaiocoe, J. (2020). *River Current Turbine Technology: Progress, Prospects and Challenges*
- Kondili, E. (2012). Special Wind Power Applications. In A. Sayigh (Ed.), *Comprehensive Renewable Energy*, 725-746. Elsevier. DOI: [10.1016/B978-0-08-087872-0.00225-0](https://doi.org/10.1016/B978-0-08-087872-0.00225-0)
- Moraes, B. Z. (2010). Análise econômico-financeira de uma pequena central hidrelétrica. (Master's thesis, Universidade Federal do Rio Grande do Sul).
- Pham, L. T. (2014). Riverine Hydrokinetic Technology: A Review. *Oregon Institute of Technology - Electrical and Renewable Energy—REE516 Term Paper*, 1-6.
- Rashki, M. R., Hejazi, K., Tamimi, V., Zeinoddini, M., & Aalami Harandi, M. M. (2022). Impacts of soft marine fouling on the hydrokinetic energy harvesting from one-degree-of-freedom vortex-induced vibrations. *Sustainable Energy Technologies and Assessments*, 54, 102881. DOI: <https://doi.org/10.1016/j.seta.2022.102881>
- Riegler, G. (1983). Principles of Energy Extraction from a Free Stream by Means of Wind Turbines. *Wind Engineering*, 7(2), 115-126.
- Sood, M., & Singal, S. K. (2022). Development of statistical relationship for the potential assessment of hydrokinetic energy. *Ocean Engineering*, 266, 112140. DOI: <https://doi.org/10.1016/j.oceaneng.2022.112140>
- Veja, F., Mendes, C., & Beluco, A. (2008). CURVAS DE CUSTO DE IMPLANTAÇÃO DE PEQUENOS PROJETOS HIDRELÉTRICOS EM FUNÇÃO DA PRODUÇÃO MÉDIA ANUAL DE ENERGIA. *PCH Notícias & SHP News*, 39, 32-35.

Vermaak, H. J., Kusakana, K., & Koko, S. P. (2014). Status of micro-hydrokinetic river technology in rural applications: A review of literature. *Renewable and Sustainable Energy Reviews*, 29, 625-633. DOI: <https://doi.org/10.1016/j.rser.2013.08.066>

Weiller, J. G. (2014). Análise de viabilidade técnica de implantação de uma PCH. (Master's thesis, FAHOR - Faculdade Horizontina).